

# 2003 CTS AMENDMENTS to the Fabrication Studies Guide to Standards and Implementation

## Summary of Curriculum Changes

### Course revisions:

- FAB2070: Gas Metal Arc Welding 1
- FAB3170: Gas Metal Arc Welding 2

### New courses:

- FAB1048: Semi-automated/Automated Welding
- FAB2048: Flux Core Arc Welding 1
- FAB3048: Flux Core Arc Welding 2

### Prerequisite change:

FAB1050: Basic Electric Welding is no longer a prerequisite for FAB2070: Gas Metal Arc Welding 1. The new prerequisite for FAB2070: Gas Metal Arc Welding 1 is FAB1048: Semi-automated/Automated Welding.

### Section B

- **Remove** pages B.5 to B.8 (Revised 2000) and **replace** with new pages B.5 to B.8 (Revised 2003).

### Section D

- **Remove** pages D.1–D.2 (Revised 2000) and **replace** with new pages D.1–D.2 (Revised 2003).
- **Add** new pages D.41 to D.46 (2003).

### Section E

- **Remove** pages E.1–E.2 and E.27 to E.30 (1997) and **replace** with new pages E.1–E.2 and E.27 to E.30 (Revised 2003).
- **Add** new pages E.67 to E.70 (2003).

### Section F

- **Remove** pages F.1–F.2 and F.65 to F.68 (1997) and **replace** with new pages F.1–F.2 and F.65 to F.70 (Revised 2003).
- **Add** new pages F.71 to F.76 (2003).

### Section G

- **Remove** page G.4 (Revised 2000) and **replace** with new page G.4 (Revised 2003).
- **Remove** pages G.45–G.46 and G.69–G.70 (1997) and **replace** with new pages G.45–G.46 and G.69–G.70 (Revised 2003).
- **Add** new pages G.77 to G.92 (2003).

### Section H

- **Remove** page H.11 (Revised 2000) and **replace** with new page H.11 (Revised 2003).

**SCOPE AND SEQUENCE**

**FABRICATION STUDIES**

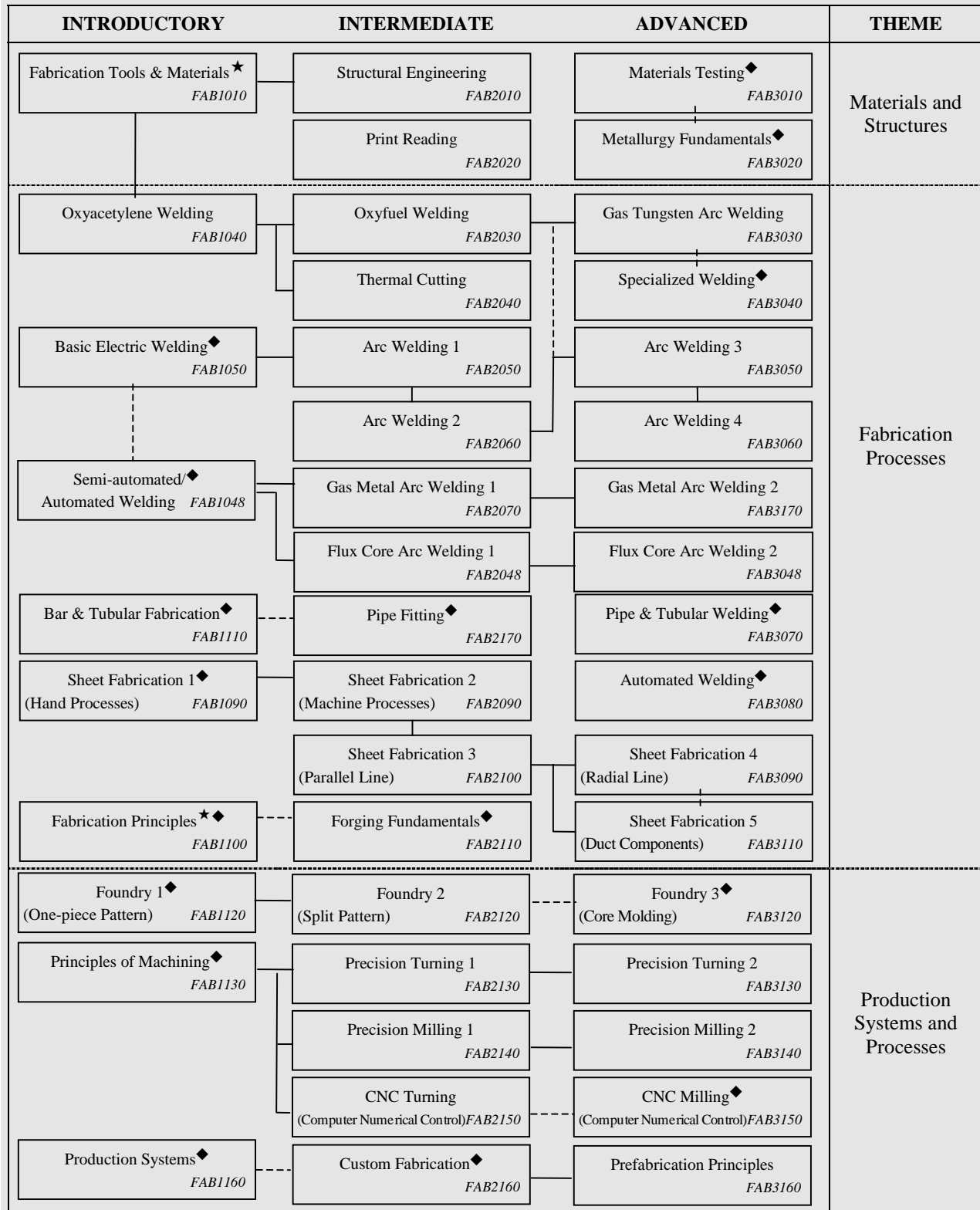

— Prerequisite

----- Recommended sequence

★ Course provides a strong foundation for further learning in this strand.

◆ Refer to specific course for additional prerequisites.

## COURSE DESCRIPTIONS

### **Course FAB1010: Fabrication Tools & Materials**

Students develop knowledge and skills in the use of basic hand tools and materials used in fabrication processes, and safely transform common metals into useful products.

### **Course FAB1040: Oxyacetylene Welding**

Students develop basic skills in the safe handling and operation of oxyacetylene equipment.

### **Course FAB1048: Semi-Automated/Automated Welding**

Students develop basic knowledge and skills related to the use of gas metal arc welding (GMAW) and flux core arc welding (FCAW) processes in both personal use and commercial applications. They also develop introductory knowledge of submerged arc welding (SAW) processes.

### **Course FAB1050: Basic Electric Welding**

Students develop basic skills related to safe use and operation of one or more common electric welding processes.

### **Course FAB1090: Sheet Fabrication 1 (Hand Processes)**

Students use basic tools, materials and processes to fabricate sheet materials into finished products, models or prototypes.

### **Course FAB1100: Fabrication Principles**

Students investigate and apply fundamental principles of fabrication to build an artifact or structure from common structural materials.

### **Course FAB1110: Bar & Tubular Fabrication**

Students use cutting, bending and fastening processes to create a variety of products from bar and tubular stock.

### **Course FAB1120: Foundry 1 (One-piece Pattern)**

Students develop the basic skills required to produce a simple one-piece pattern, a sand mold and a finished casting.

### **Course FAB1130: Principles of Machining**

Students develop basic hand and machine tool knowledge, skills and techniques to mechanically remove materials.

### **Course FAB1160: Production Systems**

Students investigate and compare the principles of production operation and the characteristics of a number of production systems.

### **Course FAB2010: Structural Engineering**

Students investigate the nature of forces and structural materials, and apply their findings to design and fabrication activities.

### **Course FAB2020: Print Reading**

Students develop basic skills in reading and interpreting working drawings to prepare a bill of materials and sequence of operations.

### **Course FAB2030: Oxyfuel Welding**

Students develop basic skills in the safe and efficient use of oxyfuel equipment and supplies to braze and fusion weld.

### **Course FAB2040: Thermal Cutting**

Students develop basic skills to use, safely and efficiently, thermal cutting equipment and supplies.

### **Course FAB2048: Flux Core Arc Welding 1**

Students develop an understanding of the advantages and disadvantages of flux core arc welding (FCAW) processes, and they gain experience using FCAW processes by performing flat, horizontal and vertical fillet welds and flat groove welds.

### **Course FAB2050: Arc Welding 1**

Students develop basic knowledge, skills and attitudes related to the operation and use of shielded metal arc welding (SMAW) equipment and accessories to make a variety of welds in the flat position.

### **Course FAB2060: Arc Welding 2**

Students identify appropriate electrodes, visually assessing a weld, and making the necessary adjustments to improve weld quality while developing horizontal position welding skills.

**Course FAB2070: Gas Metal Arc Welding 1**

Students develop an understanding of the advantages and disadvantages of gas metal arc welding (GMAW) processes, and they gain experience using GMAW processes by performing flat, horizontal and vertical fillet welds and flat groove welds.

**Course FAB2090: Sheet Fabrication 2 (Machine Processes)**

Students use basic layout, cutting, bending and fastening operations to transform common types of sheet metals into consumer products.

**Course FAB2100: Sheet Fabrication 3 (Parallel Line)**

Students expand sheet metal skills related to pattern making, seam constructing and edge treating.

**Course FAB2110: Forging Fundamentals**

Students determine the effects of heating and striking metal to change its shape and internal structure, using forging techniques.

**Course FAB2120: Foundry 2 (Split Pattern)**

Students expand their pattern making and foundry skills to produce split pattern molds and finished castings.

**Course FAB2130: Precision Turning 1**

Students develop basic turning skills to size, shape and finish common machineable metals and plastics.

**Course FAB2140: Precision Milling 1**

Students develop basic milling skills to shape and finish common machineable metals and plastics.

**Course FAB2150: CNC Turning (Computer Numerical Control)**

Students develop skills in computer assisted design (CAD) and computer numerical control (CNC) programming to manufacture a product on a CNC lathe.

**Course FAB2160: Custom Fabrication**

Students work independently, or in a cooperative learning environment, to plan and construct a product/structure that meets a specific client's needs.

**Course FAB2170: Pipe Fitting**

Students learn about the uses of pipes, basic piping principles and fabrication skills.

**Course FAB3010: Materials Testing**

Students are introduced to the principles of materials testing, and to the development and evaluation of a mechanical materials test.

**Course FAB3020: Metallurgy Fundamentals**

Students develop fundamental understandings and skills related to metallurgy, and apply these skills to fabrication processes.

**Course FAB3030: Gas Tungsten Arc Welding**

Students develop basic knowledge and skills related to the use of gas tungsten arc welding (GTAW) equipment and supplies to weld mild steel in the flat and horizontal positions.

**Course FAB3040: Specialized Welding**

Students develop specific skills associated with advanced welding techniques to join and repair metals other than low carbon steel.

**Course FAB3048: Flux Core Arc Welding 2**

Students develop skills to evaluate and improve the quality of flux core arc weldings, and they extend their flux core arc welding (FCAW) skills by performing horizontal and vertical groove welds.

**Course FAB3050: Arc Welding 3**

Students learn the role of codes and standards in the welding trade, as well as test welds and develop vertical position welding skills.

**Course FAB3060: Arc Welding 4**

Students apply and extend positional welding skills, by using a variety of common electrodes and thickness of materials.

**Course FAB3070: Pipe & Tubular Welding**

Students develop specific skills related to pipe layout, preparation of pipe/tube joints and welding techniques.

**Course FAB3080: Automated Welding**

Students investigate and describe the operation of various manual, semi-automated and automated welding processes and systems used in fabrication industries.

**Course FAB3090: Sheet Fabrication 4 (Radial Line)**

Students develop specialized skills in cylindrical and conical pattern development and seam construction of ferrous and nonferrous sheet metals.

**Course FAB3110: Sheet Fabrication 5 (Duct Components)**

Students apply and develop specialized skills in duct component pattern making and fabrication techniques.

**Course FAB3120: Foundry 3 (Core Molding)**

Students investigate and apply advanced foundry processes to produce a hollow casting, using a sand and core mold.

**Course FAB3130: Precision Turning 2**

Students develop specialized lathe skills for thread cutting and taper turning techniques.

**Course FAB3140: Precision Milling 2**

Students develop specialized skills to use vertical and/or horizontal milling machines.

**Course FAB3150: CNC Milling (Computer Numerical Control)**

Students develop skills in computer numerical control (CNC) programming to manufacture a three-dimensional product.

**Course FAB3160: Prefabrication Principles**

Students work in a cooperative learning environment to plan and construct a prefabricated product/structure to meet the specific needs of a client.

**Course FAB3170: Gas Metal Arc Welding 2**

Students develop skills to evaluate and improve the quality of gas metal arc weldings, and they extend their gas metal arc welding (GMAW) skills by performing horizontal and vertical groove welds.

# COURSE CURRICULUM AND ASSESSMENT STANDARDS:

## SECTION D: INTRODUCTORY LEVEL

The following pages define the curriculum and assessment standards for the introductory level of Fabrication Studies.

Introductory level courses help students build daily living skills and form the basis for further learning. Introductory courses are developed for students who have no previous experience in the strand.

General outcomes define the competencies a student must demonstrate to achieve success in a course. Assessment standards define the criteria and conditions to be used for assessing the competencies defined in the general outcomes.

Specific outcomes provide a detailed framework for instruction to help students build the competencies defined in the general outcomes. Additional information and suggestions for instruction are provided in the Notes column; teachers may wish to use this space to record their ideas for instruction or student projects.

Course FAB1010:	Fabrication Tools & Materials .....	D.3
Course FAB1040:	Oxyacetylene Welding .....	D.7
Course FAB1050:	Basic Electric Welding .....	D.11
Course FAB1090:	Sheet Fabrication 1 (Hand Processes) .....	D.15
Course FAB1100:	Fabrication Principles .....	D.19
Course FAB1110:	Bar & Tubular Fabrication .....	D.23
Course FAB1120:	Foundry 1 (One-piece Pattern) .....	D.27
Course FAB1130:	Principles of Machining .....	D.31
Course FAB1160:	Production Systems .....	D.37
Course FAB1048:	Semi-automated/Automated Welding .....	D.41



**COURSE FAB1048: SEMI-AUTOMATED/AUTOMATED WELDING****Level:** Introductory**Theme:** Fabrication Processes**Prerequisite:** FAB1010 Fabrication Tools & Materials**Description:** Students develop basic knowledge and skills related to the use of gas metal arc welding (GMAW) and flux core arc welding (FCAW) processes in both personal use and commercial applications. They also develop introductory knowledge of submerged arc welding (SAW) processes.**Parameters:** Access to a fabrication work centre complete with gas metal arc welding (GMAW) and/or flux core arc welding (FCAW) equipment and supplies, and to instruction from an individual with formal, specialized training in arc welding practices.**Supporting Course:** FAB1050 Basic Electric Welding**Curriculum and Assessment Standards**

General Outcomes	Assessment Criteria and Conditions	Suggested Emphasis
<p><i>The student will:</i></p> <ul style="list-style-type: none"> <li>identify health and safety hazards associated with GMAW, FCAW and SAW processes, and take preventative measures to avoid accidents and personal injury to self and others</li> </ul>	<p><i>Assessment of student achievement should be based on:</i></p> <ul style="list-style-type: none"> <li>observed performance related to: <ul style="list-style-type: none"> <li>appropriate selection and use of personal protective equipment</li> <li>maintenance of a clean and tidy work station</li> <li>safe tool/material handling and storage</li> </ul> </li> </ul> <p><i>Assessment Tool</i> <i>Fabrication Process: Light Gauge Fillet Welds, FAB1048-1</i></p> <p><i>Standard</i> <i>Performance rating of 2 for each applicable task</i></p>	10
<ul style="list-style-type: none"> <li>identify power sources used in GMAW, FCAW and SAW processes</li> </ul>	<ul style="list-style-type: none"> <li>knowledge of basic electrical terms as they relate to GMAW, FCAW and SAW processes</li> </ul> <p><i>Assessment Tool</i> <i>Presentations/Reports: Components of Semi-automated/Automated Welding, FAB1048-2</i></p> <p><i>Standard</i> <i>Performance rating of 1 for each applicable task</i></p>	10

**COURSE FAB1048: SEMI-AUTOMATED/AUTOMATED WELDING (continued)**

General Outcomes	Assessment Criteria and Conditions	Suggested Emphasis
<p><i>The student will:</i></p> <ul style="list-style-type: none"> <li>• select appropriate electrode wires and shielding gases for use in GMAW and FCAW processes</li> <li>• perform safe start-up and shut-down procedures for GMAW and/or FCAW processes</li> <li>• demonstrate safe GMAW and/or FCAW processes on light gauge mild steel and/or mild steel plate in the flat and horizontal positions</li> <li>• demonstrate basic competencies</li> </ul>	<p><i>Assessment of student achievement should be based on:</i></p> <ul style="list-style-type: none"> <li>• knowledge and observed performance related to the selection and use of appropriate electrode wires and shielding gases in GMAW and FCAW processes</li> </ul> <p><i>Assessment Tool</i>  <i>Presentations/Reports: Components of Semi-automated/Automated Welding, FAB1048-2</i></p> <p><i>Standard</i>  <i>Performance rating of 1 for each applicable task</i></p>	10
	<ul style="list-style-type: none"> <li>• demonstration of safe start-up and shut-down procedures using GMAW and/or FCAW equipment</li> </ul> <p><i>Assessment Tools</i>  <i>Equipment Checklist: GMAW/FCAW Start-up and Shut-down Procedures, FAB1048-3</i></p> <p><i>Standard</i>  <i>All procedures to be performed correctly</i></p>	20
	<ul style="list-style-type: none"> <li>• completion of light gauge fillet welds in the flat and horizontal positions</li> </ul> <p><i>Assessment Tool</i>  <i>Fabrication Process: Light Gauge Fillet Welds, FAB1048-1</i>  <i>Illustrative Example: Flat Tee Fillet Weld, FAB1048-4</i>  <i>Illustrative Example: Horizontal Lap Joint Fillet Weld, FAB1048-5</i></p> <p><i>Standard</i>  <i>Beads should be slightly convex, and of uniform width and height. Ripples are to be close, bullet shaped and free of voids, high spots, undercutting and coldlapping.</i>  <i>Performance rating of 2 for each applicable task.</i></p>	50
	<ul style="list-style-type: none"> <li>• observations of individual effort and interpersonal interaction during the learning process.</li> </ul> <p><i>Assessment Tool</i>  <i>Basic Competencies Reference Guide and any assessment tools noted above</i></p>	Integrated throughout

**COURSE FAB1048: SEMI-AUTOMATED/AUTOMATED WELDING (continued)**

Concept	Specific Outcomes	Notes
<p>Orientation</p> <ul style="list-style-type: none"> <li>• Safe Work Practices and Procedures</li> <li>• Power Sources</li> </ul>	<p><i>The student should:</i></p> <ul style="list-style-type: none"> <li>• identify and explain safety issues related to:               <ul style="list-style-type: none"> <li>– electrical shock</li> <li>– toxic fumes</li> <li>– radiant energy from the arc</li> </ul> </li> <li>• describe a safety plan in case of accident</li> <li>• identify basic components and operation principles for GMAW, FCAW and SAW processes</li> <li>• describe and compare methods of metal transfer in GMAW, FCAW and SAW processes; e.g.:               <ul style="list-style-type: none"> <li>– short arc</li> <li>– globular</li> <li>– spray arc</li> </ul> </li> <li>• explain the advantages and disadvantages of GMAW, FCAW and SAW processes</li> <li>• demonstrate knowledge of basic electrical terms; e.g.:               <ul style="list-style-type: none"> <li>– direct and alternating current</li> <li>– voltage</li> <li>– amperage</li> <li>– resistance</li> <li>– polarity</li> <li>– open circuit voltage and arc voltage</li> </ul> </li> <li>• relate knowledge of basic electrical terms to power sources used in GMAW, FCAW and SAW processes</li> <li>• identify the function of slope and inductance in CV power sources.</li> <li>• explain the advantages and disadvantages of different types of wire feed systems; e.g.:               <ul style="list-style-type: none"> <li>– push</li> <li>– pull</li> <li>– push–pull</li> </ul> </li> <li>• identify different drive roll assemblies</li> <li>• describe welding gun assemblies for GMAW and FCAW processes</li> </ul>	<p>Discuss the importance and increasing use of GMAW and FCAW processes over other welding processes in the workplace.</p> <p>As part of an ongoing expectation, students should be able to describe a plan of action in the event of a fire or accident.</p> <p>Students need to have a good understanding of electrical terms and principles for their own safety and understanding of how the welding equipment operates.</p> <p>Discuss power with respect to:</p> <ul style="list-style-type: none"> <li>• rating by current and duty cycle</li> <li>• constant voltage versus constant current.</li> </ul>







## COURSE CURRICULUM AND ASSESSMENT STANDARDS:

### SECTION E: INTERMEDIATE LEVEL

The following pages define the curriculum and assessment standards for the intermediate level of Fabrication Studies.

Intermediate level courses help students build on the competencies developed at the introductory level and focus on developing more complex competencies. They provide a broader perspective, helping students recognize the wide range of related career opportunities available within the strand.

Course FAB2010: Structural Engineering .....	E.3
Course FAB2020: Print Reading .....	E.7
Course FAB2030: Oxyfuel Welding .....	E.11
Course FAB2040: Thermal Cutting .....	E.15
Course FAB2050: Arc Welding 1 .....	E.19
Course FAB2060: Arc Welding 2 .....	E.23
Course FAB2070: Gas Metal Arc Welding 1 .....	E.27
Course FAB2090: Sheet Fabrication 2 (Machine Processes) .....	E.31
Course FAB2100: Sheet Fabrication 3 (Parallel Line) .....	E.35
Course FAB2110: Forging Fundamentals .....	E.39
Course FAB2120: Foundry 2 (Split Pattern) .....	E.43
Course FAB2130: Precision Turning 1 .....	E.47
Course FAB2140: Precision Milling 1 .....	E.51
Course FAB2150: CNC Turning (Computer Numerical Control) .....	E.55
Course FAB2160: Custom Fabrication .....	E.59
Course FAB2170: Pipe Fitting .....	E.63
Course FAB2048: Flux Core Arc Welding 1 .....	E.67



**COURSE FAB2070: GAS METAL ARC WELDING 1****Level:** Intermediate**Theme:** Fabrication Processes**Prerequisite:** FAB1048 Semi-automated/Automated Welding**Description:** Students develop an understanding of the advantages and disadvantages of gas metal arc welding (GMAW) processes, and they gain experience using GMAW processes by performing flat, horizontal and vertical fillet welds and flat groove welds.**Parameters:** Access to a fabrication work centre complete with gas metal arc welding (GMAW) equipment and supplies, and to instruction from an individual with formal, specialized training in arc welding practices.**Curriculum and Assessment Standards**

General Outcomes	Assessment Criteria and Conditions	Suggested Emphasis
<p><i>The student will:</i></p> <ul style="list-style-type: none"> <li>outline the advantages and disadvantages of GMAW processes versus other forms of arc welding processes</li> <li>describe the characteristics of a desirable gas metal arc weld</li> </ul>	<p><i>Assessment of student achievement should be based on:</i></p> <ul style="list-style-type: none"> <li>a written or oral presentation that outlines four advantages of GMAW processes over other forms of arc welding processes</li> </ul> <p><i>Assessment Tool</i> <i>Presentations/Reports: Advantages of Gas Metal Arc Welding, FAB2070-1</i></p> <p><i>Standard</i> <i>Performance rating of 2 for each applicable task</i></p>	10
	<ul style="list-style-type: none"> <li>identification and description of five visual characteristics of a weld that meets trade standards</li> </ul> <p><i>Assessment Tool</i> <i>Fabrication Process: Light Gauge Fillet Welds, FAB2070-2</i> <i>Illustrative Example:</i> <i>Vertical Lap Joint Fillet Weld, FAB2070-3</i></p> <p><i>Standard</i> <i>Performance rating of 3 for each applicable task</i></p>	10

**COURSE FAB2070: GAS METAL ARC WELDING 1 (continued)**

General Outcomes	Assessment Criteria and Conditions	Suggested Emphasis
<p><i>The student will:</i></p> <ul style="list-style-type: none"> <li>• perform safe set-up and maintenance procedures with GMAW equipment</li>   <li>• demonstrate safe GMAW practices to perform:               <ul style="list-style-type: none"> <li>– fillet welds on mild steel plate in the flat, horizontal and vertical positions</li> <li>– groove welds on mild steel plate in the flat position</li> </ul> </li>   <li>• demonstrate basic competencies</li> </ul>	<p><i>Assessment of student achievement should be based on:</i></p> <ul style="list-style-type: none"> <li>• demonstration of safe start-up, shut-down and maintenance procedures, using GMAW equipment</li> </ul> <p><i>Assessment Tools</i>  <i>Equipment Checklist: GMAW Set-up and Maintenance Procedures, FABEQUIP-6</i></p> <p><i>Standard</i>  <i>All procedures to be performed correctly</i></p> <ul style="list-style-type: none"> <li>• demonstration of safe GMAW practices and the completion of:               <ul style="list-style-type: none"> <li>– two flat, two horizontal and two vertical fillet welds on mild steel plate, using GMAW processes</li> <li>– two flat groove welds on mild steel plate, using GMAW processes</li> </ul> </li> </ul> <p><i>Assessment Tool</i>  <i>Fabrication Process: Light Gauge Fillet Welds, FAB2070-2</i>  <i>Illustrative Example: Vertical Lap Joint Fillet Weld, FAB2070-3</i></p> <p><i>Standard</i>  <i>Welds are to be free of visible structural defects and are to have uniform reinforcement</i>  <i>Performance rating of 3 for each applicable task</i></p> <ul style="list-style-type: none"> <li>• observations of individual effort and interpersonal interaction during the learning process.</li> </ul> <p><i>Assessment Tool</i>  <i>Basic Competencies Reference Guide and any assessment tools noted above</i></p>	<p>10</p> <p>70</p> <p>Integrated throughout</p>

**COURSE FAB2070: GAS METAL ARC WELDING 1 (continued)**

Concept	Specific Outcomes	Notes
<p>Orientation</p> <ul style="list-style-type: none"> <li>• Health and Safety</li> <li>• GMAW Variables</li> <li>• Weld Quality</li> </ul>	<p><i>The student should:</i></p> <ul style="list-style-type: none"> <li>• describe safety issues related to:               <ul style="list-style-type: none"> <li>– the use of personal protective equipment</li> <li>– handling and storage of consumables</li> <li>– keeping the welding area free of hazards</li> <li>– insuring adequate ventilation</li> </ul> </li> <li>• describe a safety plan in case of accident</li> <li>• identify the advantages and disadvantages of GMAW processes as compared to other arc welding processes</li> <li>• identify the variables that can directly affect weld quality; i.e.:               <ul style="list-style-type: none"> <li>– the welding current and voltage</li> <li>– modes of metal transfer; e.g.:                   <ul style="list-style-type: none"> <li>• short arc</li> <li>• globular</li> <li>• spray arc</li> </ul> </li> <li>– diameter and type of filler metal</li> <li>– type and condition of equipment</li> <li>– welding technique; e.g.:                   <ul style="list-style-type: none"> <li>• forehand or pushing</li> <li>• backhand or pulling</li> </ul> </li> </ul> </li> <li>• identify possible causes of welding defects; e.g.:               <ul style="list-style-type: none"> <li>– surface porosity</li> <li>– subsurface porosity</li> <li>– lack of fusion</li> <li>– burn through</li> <li>– lack of penetration</li> <li>– coldlapping</li> </ul> </li> <li>• identify problems common to out of position welding</li> </ul>	<p>Demonstrate forehand and backhand welding techniques.</p>

**COURSE FAB2070: GAS METAL ARC WELDING 1 (continued)**

Concept	Specific Outcomes	Notes
<p>Planning and Management</p> <ul style="list-style-type: none"> <li>• Equipment Set-up</li> <li>• Preparation</li> <li>• Equipment Maintenance</li> </ul>	<p><i>The student should:</i></p> <ul style="list-style-type: none"> <li>• apply safe work practices and procedures:               <ul style="list-style-type: none"> <li>– select and use appropriate personal protective equipment</li> <li>– maintain a clean and tidy work station</li> <li>– demonstrate safe tool/material handling and storage techniques</li> </ul> </li> <li>• for a given type of weld and/or weldment, select the appropriate:               <ul style="list-style-type: none"> <li>– wire type, size and feed rate</li> <li>– current</li> <li>– shielding gas type and flow rate</li> </ul> </li> <li>• prepare and clean all surfaces to be welded</li> <li>• properly position metal for welding</li> <li>• describe and demonstrate the maintenance required for wire drive systems and gun assemblies</li> </ul>	
<p>Implementation</p> <ul style="list-style-type: none"> <li>• Gas Metal Arc Welding</li> </ul>	<ul style="list-style-type: none"> <li>• demonstrate safe GMAW techniques and perform fillet welds in the flat, horizontal and vertical positions on mild steel plate</li> <li>• demonstrate safe GMAW techniques and perform groove welds in the flat position on mild steel plate</li> </ul>	
<p>Assessment</p> <ul style="list-style-type: none"> <li>• Quality Control</li> <li>• Career Preparation</li> </ul>	<ul style="list-style-type: none"> <li>• complete a visual inspection (i.e., non-destructive test) by observing and assessing:               <ul style="list-style-type: none"> <li>– overall size, shape and appearance of the beads</li> <li>– plate penetration</li> <li>– fusion</li> <li>– degree of undercutting and overlapping</li> </ul> </li> <li>• perform a destructive test where appropriate</li> <li>• prepare a record of completed activities within a portfolio</li> </ul>	

**COURSE FAB2048: FLUX CORE ARC WELDING 1****Level:** Intermediate**Theme:** Fabrication Processes**Prerequisite:** FAB1048 Semi-automated/Automated Welding**Description:** Students develop an understanding of the advantages and disadvantages of flux core arc welding (FCAW) processes, and gain experience using FCAW processes by performing flat, horizontal and vertical fillet welds and flat groove welds.**Parameters:** Access to a fabrication work centre complete with flux core arc welding (FCAW) equipment and supplies, and to instruction from an individual with formal, specialized training in arc welding practices.**Curriculum and Assessment Standards**

General Outcomes	Assessment Criteria and Conditions	Suggested Emphasis
<p><i>The student will:</i></p> <ul style="list-style-type: none"> <li>outline the advantages and disadvantages of FCAW processes versus other forms of arc welding processes</li> <li>describe the characteristics of a desirable flux core arc weld</li> </ul>	<p><i>Assessment of student achievement should be based on:</i></p> <ul style="list-style-type: none"> <li>a written or oral presentation that outlines four advantages of FCAW processes over other forms of arc welding processes</li> </ul> <p><i>Assessment Tool</i> <i>Presentations/Reports: Advantages of Flux Core Arc Welding, FAB2048-1</i></p> <p><i>Standard</i> <i>Performance rating of 2 for each applicable task</i></p>	10
	<ul style="list-style-type: none"> <li>identification and description of five visual characteristics of a weld that meets trade standards</li> </ul> <p><i>Assessment Tool</i> <i>Fabrication Process: Fillet and Butt Welding on Mild Steel, FAB2048-2</i></p> <p><i>Illustrative Examples:</i> <i>Flat Tee Fillet Weld, FAB2048-4</i> <i>Horizontal Tee Fillet Weld, FAB2048-5</i> <i>Vertical Tee Fillet Weld, FAB2048-6</i> <i>Flat Single Vee Butt Joint Weld, FAB2048-7</i></p> <p><i>Standard</i> <i>Performance rating of 3 for each applicable task</i></p>	10



**COURSE FAB2048: FLUX CORE ARC WELDING 1** (continued)

Concept	Specific Outcomes	Notes
<p>Orientation</p> <ul style="list-style-type: none"> <li>• Health and Safety</li> <li>• FCAW Variables</li> <li>• Weld Quality</li> </ul>	<p><i>The student should:</i></p> <ul style="list-style-type: none"> <li>• describe safety issues related to:               <ul style="list-style-type: none"> <li>– the use of personal protective equipment</li> <li>– handling and storage of consumables</li> <li>– keeping the welding area free of hazards</li> <li>– insuring adequate ventilation</li> </ul> </li> <li>• describe a safety plan in case of accident</li> <li>• identify the advantages and disadvantages of FCAW processes as compared to other arc welding processes</li> <li>• identify the variables that can directly affect weld quality; i.e.:               <ul style="list-style-type: none"> <li>– the welding current and voltage</li> <li>– modes of metal transfer; e.g.:                   <ul style="list-style-type: none"> <li>• short arc</li> <li>• globular</li> <li>• spray arc</li> </ul> </li> <li>– diameter and type of filler metal</li> <li>– type and condition of equipment</li> <li>– welding technique; e.g.:                   <ul style="list-style-type: none"> <li>• forehand or pushing</li> <li>• backhand or pulling</li> </ul> </li> </ul> </li> <li>• identify possible causes of welding defects; e.g.:               <ul style="list-style-type: none"> <li>– surface porosity</li> <li>– subsurface porosity</li> <li>– lack of fusion</li> <li>– burn through</li> <li>– lack of penetration</li> <li>– coldlapping</li> </ul> </li> <li>• identify problems common to out of position welding</li> </ul>	<p>Demonstrate forehand and backhand welding techniques.</p>

**COURSE FAB2048: FLUX CORE ARC WELDING 1** (continued)

Concept	Specific Outcomes	Notes
<p>Planning and Management</p> <ul style="list-style-type: none"> <li>• Equipment Set-up</li> <li>• Preparation</li> <li>• Equipment Maintenance</li> </ul>	<p><i>The student should:</i></p> <ul style="list-style-type: none"> <li>• apply safe work practices and procedures:                             <ul style="list-style-type: none"> <li>– select and use appropriate personal protective equipment</li> <li>– maintain a clean and tidy work station</li> <li>– demonstrate safe tool/material handling and storage techniques</li> </ul> </li> <li>• for a given type of weld and/or weldment, select the appropriate:                             <ul style="list-style-type: none"> <li>– wire type, size and feed rate</li> <li>– current</li> <li>– shielding gas type and flow rate</li> </ul> </li> <li>• prepare and clean all surfaces to be welded</li> <li>• properly position metal for welding</li> <li>• describe and demonstrate the maintenance required for wire drive systems and gun assemblies</li> </ul>	
<p>Implementation</p> <ul style="list-style-type: none"> <li>• Flux Core Arc Welding</li> </ul>	<ul style="list-style-type: none"> <li>• demonstrate safe FCAW techniques and perform fillet welds in the flat, horizontal and vertical positions on mild steel plate</li> <li>• demonstrate safe FCAW techniques and perform groove welds in the flat position on mild steel plate</li> </ul>	
<p>Assessment</p> <ul style="list-style-type: none"> <li>• Quality Control</li> <li>• Career Preparation</li> </ul>	<ul style="list-style-type: none"> <li>• complete a visual inspection (i.e., non-destructive test) by observing and assessing:                             <ul style="list-style-type: none"> <li>– overall size, shape and appearance of the beads</li> <li>– plate penetration</li> <li>– fusion</li> <li>– degree of undercutting and overlapping</li> </ul> </li> <li>• perform a destructive test where appropriate</li> <li>• prepare a record of completed activities within a portfolio</li> </ul>	

## COURSE CURRICULUM AND ASSESSMENT STANDARDS:

### SECTION F: ADVANCED LEVEL

The following pages define the curriculum and assessment standards for the advanced level of Fabrication Studies.

Advanced level courses demand a higher level of expertise and help prepare students for entry into the workplace or a related post-secondary program.

Course FAB3010: Materials Testing.....	F.3
Course FAB3020: Metallurgy Fundamentals.....	F.7
Course FAB3030: Gas Tungsten Arc Welding.....	F.13
Course FAB3040: Specialized Welding.....	F.17
Course FAB3050: Arc Welding 3.....	F.21
Course FAB3060: Arc Welding 4.....	F.25
Course FAB3070: Pipe & Tubular Welding.....	F.29
Course FAB3080: Automated Welding.....	F.33
Course FAB3090: Sheet Fabrication 4 (Radial Line).....	F.37
Course FAB3110: Sheet Fabrication 5 (Duct Components).....	F.41
Course FAB3120: Foundry 3 (Core Molding).....	F.45
Course FAB3130: Precision Turning 2.....	F.49
Course FAB3140: Precision Milling 2.....	F.53
Course FAB3150: CNC Milling (Computer Numerical Control).....	F.57
Course FAB3160: Prefabrication Principles.....	F.61
Course FAB3170: Gas Metal Arc Welding 2.....	F.65
Course FAB3048: Flux Core Arc Welding 2.....	F.71



**COURSE FAB3170: GAS METAL ARC WELDING 2****Level:** Advanced**Theme:** Fabrication Processes**Prerequisite:** FAB2070 Gas Metal Arc Welding 1**Description:** Students develop skills to evaluate and improve the quality of gas metal arc weldings, and they extend their gas metal arc welding (GMAW) skills by performing horizontal and vertical groove welds.**Parameters:** Access to a fabrication work centre complete with gas metal arc welding (GMAW) equipment and supplies, and to instruction from an individual with welding trade qualifications.**Curriculum and Assessment Standards**

General Outcomes	Assessment Criteria and Conditions	Suggested Emphasis
<p><i>The student will:</i></p> <ul style="list-style-type: none"> <li>identify variables that affect the quality of gas metal arc welds, and identify strategies to evaluate and improve weld quality</li> </ul>	<p><i>Assessment of student achievement should be based on:</i></p> <ul style="list-style-type: none"> <li>assessment, based on trade standards, of a gas metal arc weld; assessment to focus attention on:               <ul style="list-style-type: none"> <li>variables affecting weld quality</li> <li>possible causes of observed defects</li> <li>corrective measures to improve weld quality</li> </ul> </li> </ul> <p><i>Assessment Tools</i>  <i>Fabrication Process: Fillet and Butt Welding on Mild Steel, FAB3170-1</i>  <i>Illustrative Example:</i>  <i>Horizontal Single Vee Butt Joint Weld, FAB3170-2</i></p> <p><i>Standard</i>  <i>Performance rating of 3 for each applicable task</i></p>	10
	<ul style="list-style-type: none"> <li>perform safe set-up, maintenance and troubleshooting procedures with GMAW equipment</li> </ul>	<ul style="list-style-type: none"> <li>demonstration of safe start-up, shut-down, maintenance and troubleshooting procedures, using GMAW equipment</li> </ul> <p><i>Assessment Tools</i>  <i>Equipment Checklist: GMAW Start-Up and Shut-Down Procedures, FABEQUIP-6</i></p> <p><i>Standard</i>  <i>All procedures to be performed correctly</i></p>



**COURSE FAB3170: GAS METAL ARC WELDING 2 (continued)**

Concept	Specific Outcomes	Notes
<p>Orientation</p> <ul style="list-style-type: none"> <li>• Health and Safety</li> <li>• GMAW Variables</li> <li>• Gas Mixtures</li> <li>• Filler Metals</li> <li>• Arc Control</li> </ul>	<p><i>The student should:</i></p> <ul style="list-style-type: none"> <li>• describe safety issues related to:               <ul style="list-style-type: none"> <li>– the use of personal protective equipment</li> <li>– handling and storage of consumables</li> <li>– keeping the welding area free of hazards</li> <li>– insuring adequate ventilation</li> </ul> </li> <li>• describe a safety plan in case of accident</li> <li>• identify the variables that can directly affect weld quality; i.e.:               <ul style="list-style-type: none"> <li>– the welding current and voltage</li> <li>– type of shielding gas/flux</li> <li>– diameter and type of filler metal</li> <li>– type and condition of equipment</li> <li>– welding technique</li> </ul> </li> <li>• select the appropriate shielding gas mixture based on:               <ul style="list-style-type: none"> <li>– mode of metal transfer</li> <li>– base metal type and thickness</li> <li>– joint design</li> <li>– filler material</li> <li>– desired weld quality</li> </ul> </li> <li>• describe how to select the type and size of filler metal</li> <li>• explain how to avoid contamination of filler materials</li> <li>• identify the relationship between:               <ul style="list-style-type: none"> <li>– wire speed and amperage</li> <li>– welding voltage and arc length</li> </ul> </li> <li>• describe the effects of:               <ul style="list-style-type: none"> <li>– backhand or pull welding</li> <li>– forehand or push welding</li> </ul> </li> <li>• describe the effects of torch angle on:               <ul style="list-style-type: none"> <li>– weld penetration</li> <li>– weld appearance</li> </ul> </li> </ul>	<p>Explain how the following affect weld quality:</p> <ul style="list-style-type: none"> <li>• voltage</li> <li>• amperage</li> <li>• polarity</li> <li>• electrode extension.</li> </ul> <p>Discuss the properties and uses of:</p> <ul style="list-style-type: none"> <li>• inert gases; e.g., argon, helium</li> <li>• reactive gases; e.g., carbon dioxide, oxygen, hydrogen, nitrogen</li> <li>• shielding gas mixes; e.g., argon-oxygen, argon-carbon dioxide, argon-helium, argon-helium-carbon dioxide, argon-carbon dioxide-hydrogen.</li> </ul> <p>Demonstrate backhand and forehand welding techniques.</p>

**COURSE FAB3170: GAS METAL ARC WELDING 2 (continued)**

Concept	Specific Outcomes	Notes
<p>Planning and Management</p> <ul style="list-style-type: none"> <li>• Equipment Set-up</li> <li>• Preparation</li> <li>• Equipment Maintenance/Repair</li> </ul>	<p><i>The student should:</i></p> <ul style="list-style-type: none"> <li>• apply safe work practices and procedures to:               <ul style="list-style-type: none"> <li>– select and use appropriate personal protective equipment</li> <li>– maintain a clean and tidy work station</li> <li>– demonstrate safe tool/material handling and storage techniques</li> </ul> </li> <li>• for a given type of weld and/or weldment, select the appropriate:               <ul style="list-style-type: none"> <li>– wire type, size and feed rate</li> <li>– current</li> <li>– shielding gas type and flow rate</li> </ul> </li> <li>• select the proper fit-up for a given weld</li> <li>• prepare and clean all surfaces to be welded</li> <li>• properly position metal for welding</li> <li>• perform maintenance required for wire drive systems and gun assemblies</li> <li>• diagnose and demonstrate corrective measures for malfunctioning GMAW equipment</li> </ul>	
<p>Implementation</p> <ul style="list-style-type: none"> <li>• Gas Metal Arc Welding</li> <li>• Troubleshooting</li> </ul>	<ul style="list-style-type: none"> <li>• demonstrate safe GMAW techniques and perform groove welds in the horizontal and vertical positions on mild steel plate</li> <li>• describe corrective actions that can be taken to avoid:               <ul style="list-style-type: none"> <li>– surface porosity</li> <li>– subsurface porosity</li> <li>– lack of fusion</li> <li>– burn through</li> <li>– lack of penetration</li> <li>– coldlapping</li> </ul> </li> <li>• identify problems common to out of position welding</li> </ul>	





**COURSE FAB3048: FLUX CORE ARC WELDING 2****Level:** Advanced**Theme:** Fabrication Processes**Prerequisite:** FAB2048 Flux Core Arc Welding 1**Description:** Students develop skills to evaluate and improve the quality of flux core arc weldings, and they extend their flux core arc welding (FCAW) skills by performing horizontal and vertical groove welds.**Parameters:** Access to a fabrication work centre complete with flux core arc welding (FCAW) equipment and supplies, and to instruction from an individual with welding trade qualifications.**Curriculum and Assessment Standards**

General Outcomes	Assessment Criteria and Conditions	Suggested Emphasis
<p><i>The student will:</i></p> <ul style="list-style-type: none"> <li>identify variables that affect the quality of flux core arc welds, and identify strategies to evaluate and improve weld quality</li> </ul>	<p><i>Assessment of student achievement should be based on:</i></p> <ul style="list-style-type: none"> <li>assessment, based on trade standards, of a flux core arc weld; assessment to focus attention on: <ul style="list-style-type: none"> <li>variables affecting weld quality</li> <li>possible causes of observed defects</li> <li>corrective measures to improve weld quality</li> </ul> </li> </ul> <p><i>Assessment Tools</i>  <i>Fabrication Process: Fillet and Butt Welding on Mild Steel, FAB3048-1</i>  <i>Illustrative Examples:</i>  <i>Horizontal Single Vee Butt Joint Weld, FAB3048-3</i>  <i>Vertical Single Vee Butt Joint Weld, FAB3048-4</i></p> <p><i>Standard</i>  <i>Performance rating of 3 for each applicable task</i></p>	10
<ul style="list-style-type: none"> <li>perform safe set-up, maintenance and troubleshooting procedures with FCAW equipment</li> </ul>	<ul style="list-style-type: none"> <li>demonstration of safe start-up, shut-down, maintenance and troubleshooting procedures, using FCAW equipment</li> </ul> <p><i>Assessment Tools</i>  <i>Equipment Checklist: FCAW Set-up, Maintenance and Troubleshooting Procedures, FAB3048-2</i></p> <p><i>Standard</i>  <i>All procedures to be performed correctly</i></p>	10



**COURSE FAB3048: FLUX CORE ARC WELDING 2** (continued)

Concept	Specific Outcomes	Notes
<p>Orientation</p> <ul style="list-style-type: none"> <li>• Health and Safety</li> <li>• FCAW Variables</li> <li>• Gas Mixtures</li> <li>• Filler Metals</li> <li>• Arc Control</li> </ul>	<p><i>The student should:</i></p> <ul style="list-style-type: none"> <li>• describe safety issues related to:               <ul style="list-style-type: none"> <li>– the use of personal protective equipment</li> <li>– handling and storage of consumables</li> <li>– keeping the welding area free of hazards</li> <li>– insuring adequate ventilation</li> </ul> </li> <li>• describe a safety plan in case of accident</li> <li>• identify the variables that can directly affect weld quality; i.e.:               <ul style="list-style-type: none"> <li>– the welding current and voltage</li> <li>– type of shielding gas/flux</li> <li>– diameter and type of filler metal</li> <li>– type and condition of equipment</li> <li>– welding technique</li> </ul> </li> <li>• select the appropriate shielding gas mixture based on:               <ul style="list-style-type: none"> <li>– mode of metal transfer</li> <li>– base metal type and thickness</li> <li>– joint design</li> <li>– filler material</li> <li>– desired weld quality</li> </ul> </li> <li>• describe how to select the type and size of filler metal</li> <li>• explain how to avoid contamination of filler materials</li> <li>• identify the relationship between:               <ul style="list-style-type: none"> <li>– wire speed and amperage</li> <li>– welding voltage and arc length</li> </ul> </li> <li>• describe the effects of:               <ul style="list-style-type: none"> <li>– backhand or pull welding</li> <li>– forehand or push welding</li> </ul> </li> <li>• describe the effects of torch angle on:               <ul style="list-style-type: none"> <li>– weld penetration</li> <li>– weld appearance</li> </ul> </li> </ul>	<p>Explain how the following affect weld quality:</p> <ul style="list-style-type: none"> <li>• voltage</li> <li>• amperage</li> <li>• polarity</li> <li>• electrode extension.</li> </ul> <p>Discuss the properties and uses of:</p> <ul style="list-style-type: none"> <li>• inert gases; e.g., argon, helium</li> <li>• reactive gases; e.g., carbon dioxide, oxygen, hydrogen, nitrogen</li> <li>• shielding gas mixes; e.g., argon-oxygen, argon-carbon dioxide, argon-helium, argon-helium-carbon dioxide, argon-carbon dioxide-hydrogen.</li> </ul> <p>Describe the filler metal classification for typical flux-cored wire; e.g.:</p> <ul style="list-style-type: none"> <li>• E 480 1 T – 6 CH</li> <li>• E – XXT – XM JHZ.</li> </ul> <p>Demonstrate backhand and forehand welding techniques.</p>

**COURSE FAB3048: FLUX CORE ARC WELDING 2** (continued)

Concept	Specific Outcomes	Notes
<p>Planning and Management</p> <ul style="list-style-type: none"> <li>• Equipment Set-up</li> <li>• Preparation</li> <li>• Equipment Maintenance/Repair</li> </ul>	<p><i>The student should:</i></p> <ul style="list-style-type: none"> <li>• apply safe work practices and procedures to:               <ul style="list-style-type: none"> <li>– select and use appropriate personal protective equipment</li> <li>– maintain a clean and tidy work station</li> <li>– demonstrate safe tool/material handling and storage techniques</li> </ul> </li> <li>• for a given type of weld and/or weldment, select the appropriate:               <ul style="list-style-type: none"> <li>– wire type, size and feed rate</li> <li>– current</li> <li>– shielding gas type and flow rate</li> </ul> </li> <li>• select the proper fit-up for a given weld</li> <li>• prepare and clean all surfaces to be welded</li> <li>• properly position metal for welding</li> <li>• perform maintenance required for wire drive systems and gun assemblies</li> <li>• diagnose and demonstrate corrective measures for malfunctioning FCAW equipment</li> </ul>	
<p>Implementation</p> <ul style="list-style-type: none"> <li>• Flux Core Arc Welding</li> <li>• Troubleshooting</li> </ul>	<ul style="list-style-type: none"> <li>• demonstrate safe FCAW techniques and perform groove welds in the horizontal and vertical positions on mild steel plate</li> <li>• describe corrective actions that can be taken to avoid:               <ul style="list-style-type: none"> <li>– surface porosity</li> <li>– subsurface porosity</li> <li>– lack of fusion</li> <li>– burn through</li> <li>– lack of penetration</li> <li>– coldlapping</li> </ul> </li> <li>• identify problems common to out of position welding</li> </ul>	

**COURSE FAB3048: FLUX CORE ARC WELDING 2** (continued)

Concept	Specific Outcomes	Notes
<p>Assessment</p> <ul style="list-style-type: none"> <li>• Quality Control</li>   <li>• Career Preparation</li> </ul>	<p><i>The student should:</i></p> <ul style="list-style-type: none"> <li>• complete a visual inspection (i.e., non-destructive test) by observing and assessing:               <ul style="list-style-type: none"> <li>– overall size, shape and appearance of beads</li> <li>– plate penetration</li> <li>– fusion</li> <li>– degree of undercutting and overlapping</li> </ul> </li> <li>• perform a destructive test where appropriate</li>   <li>• prepare a record of completed activities within a portfolio</li> <li>• explain employment and further training opportunities for FCAW</li> </ul>	



## TABLE OF CONTENTS

### ASSESSING STUDENT ACHIEVEMENT

Assessing Student Achievement in CTS .....	G.5
Assessing Student Achievement in Fabrication Studies .....	G.7

#### Assessment Tools Generic to CTS:

Basic Competencies Reference Guide .....	G.8
Generic Rating Scale .....	G.10

#### Frameworks for Assessment:

CTSISS: Issue Analysis .....	G.11
CTSLAB: Lab Investigations .....	G.12
CTSNEG: Negotiation and Debate .....	G.13
CTSPRE: Presentations/Reports .....	G.14
CTSRES: Research Process .....	G.15

#### Assessment Tools Generic to Fabrication Studies Strand:

FABACT: Assessment Framework: Activity Assessment .....	G.16
FABPRD: Assessment Framework: Product Assessment .....	G.17
FABPRS: Assessment Framework: Fabrication Process .....	G.18

#### Assessment Tools Specific to Courses in the Fabrication Studies Strand:

FAB1010–1: Presentations/Reports: Hand Tools .....	G.19
FAB1010–2: Illustrative Example: Hand Tool Presentation .....	G.20
FAB1010–3: Presentations/Reports: Material Identification .....	G.21
FAB1040–1: Fabrication Process: Basic Oxyacetylene Welding .....	G.22
FAB1040–2: Illustrative Example: Basic Oxyacetylene Welding .....	G.23
FAB1050–1: Fabrication Process: Electric Welding .....	G.24
FAB1050–2: Illustrative Example: Flat Lap Joint Fillet Weld .....	G.25
FAB1090–1: Product Assessment: Working with Sheet Stock .....	G.26
FAB1100–1: Response Assessment: Principles of Fabrication .....	G.27
FAB1100–2: Issue Analysis: Fastening Systems .....	G.28
FAB1110–1: Presentations/Reports: Bar and Tubular Stock .....	G.29
FAB1110–2: Product Assessment: Working with Bar Stock .....	G.30
FAB1120–1: Product Assessment: Sand Casting .....	G.31
FAB1130–1: Response Assessment: Machining Materials and Processes .....	G.32
FAB1130–2: Product Assessment: Basic Machining .....	G.33
FAB1160–1: Presentations/Reports: Planning a Production System .....	G.34
FAB2010–1: Presentations/Reports: Building Structures .....	G.35
FAB2020–1: Response Assessment: Print Reading Applications .....	G.36
FAB2030–1: Fabrication Process: Basic Oxyfuel Welding .....	G.37
FAB2030–2: Illustrative Example: Vertical Butt Joint Fusion Weld .....	G.38
FAB2050–1: Fabrication Process: Basic Arc Welding .....	G.39
FAB2050–2: Illustrative Example: Flat Lap Joint Fillet Weld .....	G.40
FAB2060–1: Response Assessment: Electrode Coding .....	G.41
FAB2060–2: Fabrication Process: Horizontal Lap and Tee Joints .....	G.42
FAB2060–3: Illustrative Example: Horizontal Tee Joint – Single Pass .....	G.43
FAB2070–1: Presentations/Reports: Advantages of Gas Metal Arc Welding .....	G.44
FAB2070–2: Fabrication Process: Light Gauge Fillet Welds .....	G.45
FAB2070–3: Illustrative Example: Vertical Lap Joint Fillet Weld .....	G.46
FAB2090–1: Product Assessment: Basic Sheet Metal Products .....	G.47
FAB2100–1: Product Assessment: Parallel Line Developments .....	G.48
FAB2110–1: Product Assessment: Forge Work .....	G.49

FAB2120-1:	Response Assessment: Split Pattern and Mold Making .....	G.50
FAB2120-2:	Activity Assessment: Pattern Work and Mold Making .....	G.51
FAB2130-1:	Fabrication Process: Straight Turning .....	G.52
FAB2130-2:	Illustrative Example: Screwdriver .....	G.53
FAB2140-1:	Fabrication Process: Mill Work .....	G.55
FAB2140-2:	Illustrative Example: Aluminum Dice .....	G.56
FAB2160-1:	Product Assessment: Custom Work .....	G.57
FAB2170-1:	Research Process: Piping Systems .....	G.58
FAB3010-1:	Lab Investigations: Testing Materials .....	G.59
FAB3030-1:	Fabrication Process: Tungsten Arc Welding .....	G.60
FAB3050-1:	Fabrication Process: Vertical Lap and Tee Joints .....	G.61
FAB3050-2:	Illustrative Example: Vertical Outside Corner – Multi-pass .....	G.62
FAB3060-1:	Fabrication Process: Butt Joint Welds .....	G.63
FAB3060-2:	Illustrative Example: Flat Vee-groove Butt Joint .....	G.64
FAB3070-1:	Fabrication Process: Joint Preparation and Welding .....	G.65
FAB3160-1:	Product Assessment: Prefabricated Project .....	G.66
FAB3160-2:	Illustrative Example: Gear Puller .....	G.67
FAB3170-1:	Fabrication Process: Fillet and Butt Welding on Mild Steel .....	G.69
FAB3170-2:	Illustrative Example: Horizontal Single Vee Butt Joint Weld .....	G.70
FABEQUIP-1:	Equipment Checklist: Drill Press .....	G.71
FABEQUIP-2:	Equipment Checklist: Grinder-Bench or Pedestal .....	G.72
FABEQUIP-3:	Equipment Checklist: Metal Lathe .....	G.73
FABEQUIP-4:	Equipment Checklist: Milling Machines .....	G.74
FABEQUIP-5:	Equipment Checklist: OAW Start-up and Shut-down Procedures .....	G.75
FABEQUIP-6:	Equipment Checklist: GMAW Start-up and Shut-down Procedures .....	G.76
FAB1048-1:	Fabrication Process: Light Gauge Fillet Welds .....	G.77
FAB1048-2:	Presentations/Reports: Components of Semi-automated/Automated Welding .....	G.78
FAB1048-3:	Equipment Checklist: GMAW/FCAW Start-Up and Shut-down Procedures .....	G.79
FAB1048-4:	Illustrative Example: Flat Tee Fillet Weld .....	G.80
FAB1048-5:	Illustrative Example: Horizontal Lap Joint Fillet Weld .....	G.81
FAB2048-1:	Presentations/Reports: Advantages of Flux Core Arc Welding .....	G.82
FAB2048-2:	Fabrication Process: Fillet and Butt Welding on Mild Steel .....	G.83
FAB2048-3:	Equipment Checklist: FCAW Set-Up and Maintenance Procedures .....	G.84
FAB2048-4:	Illustrative Example: Flat Tee Fillet Weld .....	G.85
FAB2048-5:	Illustrative Example: Horizontal Tee Fillet Weld .....	G.86
FAB2048-6:	Illustrative Example: Vertical Tee Fillet Weld .....	G.87
FAB2048-7:	Illustrative Example: Flat Single Vee Butt Joint Weld .....	G.88
FAB3048-1:	Fabrication Process: Fillet and Butt Welding on Mild Steel .....	G.89
FAB3048-2:	Equipment Checklist: FCAW Set-Up, Maintenance and Troubleshooting Procedure .....	G.90
FAB3048-3:	Illustrative example: Horizontal Single Vee Butt Joint Weld .....	G.91
FAB3048-4:	Illustrative Example: Vertical Single Vee Butt Joint Weld .....	G.92

**General Outcomes**

*The student will:*

- describe the characteristics of a desirable gas metal arc weld
- demonstrate safe GMAW practices to perform:
  - fillet welds on mild steel plate in the flat, horizontal and vertical positions
  - groove welds on mild steel plate in the flat position

**Standard**

Performance rating of 3 for each applicable task.

**Rating Scale**

*The student:*

- 4 exceeds defined outcomes. Plans and solves problems effectively and creatively in a self-directed manner. Tools, materials and/or processes are selected and used efficiently, effectively and with confidence. *Quality, particularly details and finishes, and productivity are consistent and exceed standards.*
- 3 meets defined outcomes. Plans and solves problems in a self-directed manner. Tools, materials and/or processes are selected and used efficiently and effectively. *Quality and productivity are consistent.*
- 2 meets defined outcomes. Plans and solves problems with limited assistance. Tools, materials and/or processes are selected and used appropriately. *Quality and productivity are reasonably consistent.*
- 1 meets defined outcomes. Follows a guided plan of action. A limited range of tools, materials and/or processes are used appropriately. *Quality and productivity are reasonably consistent.*
- 0 has not completed defined outcomes. Tools, materials and/or processes are used inappropriately.

**TASK PERFORMANCE CRITERIA**

*The student:*

**Preparation and Planning**

- prepares self for task
- organizes and works in an orderly manner
- interprets and carries out instructions accurately
- thinks through problems before asking for help
- reads weld specifications to determine:
  - weld type and position
  - type of weldment
  - type of filler metal
  - equipment settings
  - welding techniques
- understands first aid treatment for minor cuts, burns and bruises
- identifies appropriate personal protective equipment (PPE) and ventilation controls

**Use of Equipment and Materials**

- wears the proper PPE
- follows accepted start-up, operation and shut-down procedures
- recognizes potential health and safety hazards

**Use of Equipment and Materials (continued)**

- measures accurately
- carries out proper fit-up procedures
- selects the correct type of electrode and wire gauge
- adjusts equipment according to the weld specification and manufacturer’s recommendations
- manipulates the gun and electrode as instructed
- cleans weld appropriately
- stores and disposes materials as instructed
- fulfills given clean-up responsibilities

**Task Performance**

- produces two or more acceptable:
  - lap joints on available light gauge mild steel in the horizontal and vertical positions
  - tee joints on available light gauge mild steel in the horizontal and vertical positions
- evaluates a given weld according to:
  - overall appearance
  - weld profile
  - plate penetration
  - degree of undercutting and coldlapping
  - slag inclusions if using flux core wire

**PERFORMANCE ASSESSMENT**

CRITERIA	STUDENT RATING					STANDARD	COMMENTS
Preparation and Planning	4	3	2	1	0	3	
Use of Equipment and Materials	4	3	2	1	0	3	
Task Performance	4	3	2	1	0	3	

**General Outcomes**

*The student will:*

- describe the characteristics of a desirable gas metal arc weld
- demonstrate safe GMAW practices and perform:
  - fillet welds on mild steel plate in the flat, horizontal and vertical positions
  - groove welds on mild steel plate in the flat position

**PROCEDURE**

Weld Type:	Lap Joint Fillet Weld
Position:	horizontal
Base Metal:	2 – 1 1/2" x 6" (38 mm x 150 mm) 10–14 gauge mild steel
Preparation:	wire brush to remove rust, oil and scale
Filler Metal:	0.035" (0.9 mm) ER70S
Shielding Gas	CO <sub>2</sub>
Number of Passes:	one
Machine Set-up:	as recommended by manufacturer
Fit-up:	overlap 1/8" (3 mm) tight fitting, tacked at both ends
Manipulation:	weld both sides of joint. Forehand first side and backhand second side.

**Task Performance Appraisal**

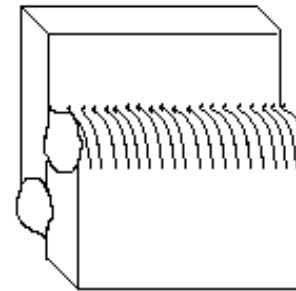

**Desirable Weld**

Beads should be slightly convex and of uniform width and height. Ripples are to be close, bullet shaped and free of voids, high spots, undercutting and cold lapping. Both legs should be equal to the thickness of the base metal.

**Acceptable Weld**

Beads should be slightly convex and evenly spaced. Evidence of voids, undercutting and cold lapping should be minimal. Legs should not be less than the thickness of the base metal.

**Comments:**

**General Outcomes**

*The student will:*

- identify variables that affect the quality of gas metal arc welds, and identify strategies to evaluate and improve weld quality
- demonstrate safe GMAW practices to perform groove welds on mild steel plate in the horizontal and vertical positions

**Standard**

Performance rating of 3 for each applicable task.

**Rating Scale**

*The student:*

- 4 exceeds defined outcomes. Plans and solves problems effectively and creatively in a self-directed manner. Tools, materials and/or processes are selected and used efficiently, effectively and with confidence. *Quality, particularly details and finishes, and productivity are consistent and exceed standards.*
- 3 meets defined outcomes. Plans and solves problems in a self-directed manner. Tools, materials and/or processes are selected and used efficiently and effectively. *Quality and productivity are consistent.*
- 2 meets defined outcomes. Plans and solves problems with limited assistance. Tools, materials and/or processes are selected and used appropriately. *Quality and productivity are reasonably consistent.*
- 1 meets defined outcomes. Follows a guided plan of action. A limited range of tools, materials and/or processes are used appropriately. *Quality and productivity are reasonably consistent.*
- 0 has not completed defined outcomes. Tools, materials and/or processes are used inappropriately.

**TASK PERFORMANCE CRITERIA**

*The student:*

**Preparation and Planning**

- prepares self for task and develops an effective work plan
- interprets and carries out instructions accurately
- plans and uses time in a logical manner
- attempts to solve problems prior to requesting help
- reads weld specifications and drawings to determine:
  - type of weld and position
  - type of weldment and filler metal
  - equipment settings
  - welding techniques
- identifies appropriate personal protective equipment (PPE) and ventilation controls

**Content**

- lists and describes the characteristics of a desirable weld and test methods
- discusses strategies to improve weld quality related to:
  - mode of metal transfer
  - type of filler metal
  - machine set-up
  - manipulation

**Use of Equipment and Materials**

- wears the proper PPE
- follows accepted start-up, operation and shut-down procedures
- recognizes and corrects potential health and safety hazards
- maintains equipment according to the manufacturers' recommendations
- fulfills clean-up responsibilities

**Task Performance**

- produces two or more acceptable multi-pass fillet and butt welds in the:
  - flat
  - horizontal
  - vertical
 positions using gas metal and/or flux core processes

**PERFORMANCE ASSESSMENT**

CRITERIA	STUDENT RATING					STANDARD	COMMENTS
Preparation and Planning	4	3	2	1	0	3	
Content	4	3	2	1	0	3	
Use of Equipment and Materials	4	3	2	1	0	3	
Task Performance	4	3	2	1	0	3	

**General Outcomes**

*The student will:*

- identify variables that affect the quality of gas metal arc welds, and identify strategies to evaluate and improve weld quality
- demonstrate safe GMAW practices to perform groove welds on mild steel plate in the horizontal and vertical positions

**PROCEDURE**

Weld Type:	Single Vee Butt Joint
Position:	horizontal
Base Metal:	2 – 3/8" x 2" x 5" (10 mm x 50 mm x 125 mm) mild steel plate
Preparation:	30° bevel, 1/16" (2 mm) land, wire brush to remove oxides
Filler Metal:	0.035" (0.9 mm) ER70S
Shielding Gas	CO <sub>2</sub>
Number of Passes:	three to four stringer beads
Machine Set-up	according to the manufacturer's recommendations
Fit Up	5/32" (4 mm) root opening, tack on each end
Manipulation:	½ included angle with gravity correction. 15°–30° backhand root pass.

**Task Performance Appraisal**

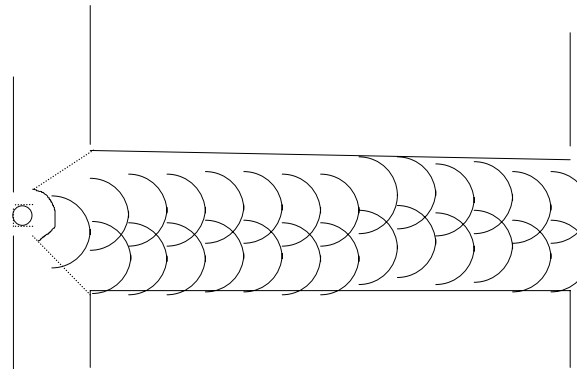

**Desirable Weld**

There should be evidence of complete penetration. Beads should be straight and evenly spaced. Build up should be slightly higher than base metal. Excessive spatter on surface should not be evident.

**Acceptable Weld**

Each pass should be smooth and free of high spots and voids. Penetration should be complete and evidence of spatter should be minimal.

**Comments:**

**General Outcomes**

*The student will:*

- identify health and safety hazards associated with GMAW, FCAW and SAW processes, and take preventative measures to avoid accidents and personal injury to self and others
- demonstrate safe GMAW and/or FCAW processes on light gauge mild steel and/or mild steel plate in the flat and horizontal positions

**Standard**  
Performance rating of 2 for each applicable task.

**Rating Scale**

- The student:*
- 4 exceeds defined outcomes. Plans and solves problems effectively and creatively in a self-directed manner. Tools, materials and/or processes are selected and used efficiently, effectively and with confidence. *Quality, particularly details and finishes, and productivity are consistent and exceed standards.*
  - 3 meets defined outcomes. Plans and solves problems in a self-directed manner. Tools, materials and/or processes are selected and used efficiently and effectively. *Quality and productivity are consistent.*
  - 2 meets defined outcomes. Plans and solves problems with limited assistance. Tools, materials and/or processes are selected and used appropriately. *Quality and productivity are reasonably consistent.*
  - 1 meets defined outcomes. Follows a guided plan of action. A limited range of tools, materials and/or processes are used appropriately. *Quality and productivity are reasonably consistent.*
  - 0 has not completed defined outcomes. Tools, materials and/or processes are used inappropriately.

**TASK PERFORMANCE CRITERIA**

*The student:*

**Preparation and Planning**

- prepares self for task
- identifies appropriate personal protective equipment and ventilation controls
- organizes and works in an orderly manner
- interprets and carries out instructions accurately
- understands first-aid treatment for minor cuts, burns and bruises
- reads weld specifications to determine:
  - weld type and position
  - type of weldment
  - type of filler metal
  - equipment settings
  - welding techniques

**Use of Equipment and Materials**

- wears appropriate personal protective equipment
- follows accepted start-up, operation and shut-down procedures
- recognizes potential health and safety hazards
- measures accurately
- carries out proper fit-up procedures
- selects the correct type of electrode and wire gauge
- adjusts equipment according to weld specifications and manufacturer’s recommendations
- manipulates the gun and electrode as instructed
- cleans weld appropriately
- stores and disposes materials as instructed

**Content/Theory**

- describes GMAW, FCAW and SAW equipment and processes
- lists four advantages of GMAW, FCAW and SAW processes; e.g.:
  - welding is continuous and therefore faster
  - minimum weld clean-up
  - can be used with ferrous and non-ferrous materials
  - results in less zone affected by heat
- lists two advantages and two disadvantages of each of the following methods of metal transfer:
  - short circuit
  - globular
  - spray

**Task Performance**

- produces two or more acceptable:
  - lap joint welds on light gauge mild steel in the horizontal and vertical positions
  - tee joint welds on light gauge mild steel in the horizontal and vertical positions
- evaluates a given weld according to:
  - overall appearance
  - weld profile
  - plate penetration
  - degree of undercutting and coldlapping
  - slag inclusions (if using flux core wire)

**PERFORMANCE ASSESSMENT**

CRITERIA	STUDENT RATING	STANDARD	COMMENTS
Preparation and Planning	4 3 2 1 0	3	
Use of Equipment and Materials	4 3 2 1 0	3	
Content/Theory	4 3 2 1 0	3	
Task Performance	4 3 2 1 0	3	

**PRESENTATIONS/REPORTS: COMPONENTS OF SEMI-AUTOMATED/  
AUTOMATED WELDING**

**Semi-automated/Automated Welding: FAB1048–2**

**General Outcomes**

*The student will:*

- identify power sources used in GMAW, FCAW and SAW processes
- select appropriate electrode wires and shielding gases for use in GMAW and FCAW processes

**Standard**

Performance rating of 1 for each applicable task.

**Rating Scale**

*The student:*

- 4 exceeds defined outcomes. Plans and solves problems effectively and creatively in a self-directed manner. Tools, materials and/or processes are selected and used efficiently, effectively and with confidence. *Quality, particularly details and finishes, and productivity are consistent and exceed standards.*
- 3 meets defined outcomes. Plans and solves problems in a self-directed manner. Tools, materials and/or processes are selected and used efficiently and effectively. *Quality and productivity are consistent.*
- 2 meets defined outcomes. Plans and solves problems with limited assistance. Tools, materials and/or processes are selected and used appropriately. *Quality and productivity are reasonably consistent.*
- 1 meets defined outcomes. Follows a guided plan of action. A limited range of tools, materials and/or processes are used appropriately. *Quality and productivity are reasonably consistent.*
- 0 has not completed defined outcomes. Tools, materials and/or processes are used inappropriately.

**TASK PERFORMANCE CRITERIA**

*The student:*

**Preparation and Planning**

- sets goals and describes steps to achieve them
- uses personal initiative to formulate questions and find answers
- plans and uses time effectively

**Content/Theory**

- lists power sources used in SMAW, GMAW, GTAW, FCAW and SAW processes
- identifies the four types of drive roll configurations and their applications
- describes changes that occur as the slope is adjusted
- describes the effect of inductance on weld quality
- explains appropriate uses of push, pull and push-pull feed systems
- describes different types of gun configurations
- defines terms associated with GMAW and FCAW wire; e.g., flux, composite wire, stickout
- describes methods of fabricating solid (GMAW) and tubular (FCAW) wire
- explains the difference between the following designations and types of wire:
  - Canadian Standards Association (CSA) and American Welding Society (AWS)
  - gas metal arc welding (GMAW) and flux core arc welding (FCAW)
- explains the purpose of sealed containers and spool covers

**Content/Theory (continued)**

- lists possible problems caused by damp wire, rusty wire and a clogged liner
- explains the benefits of using shielding gas; i.e.:
  - oxides
  - nitrates
- explains the effects that shielding gases have on the welding process; e.g.:
  - method of metal transfer
  - tendency to undercut
  - cleaning action
  - speed of welding
  - mechanical/chemical properties of weld
  - weld profile
- explains the difference between a shielding gas and a shielding gas mixture
- lists the gases used in spray transfer and FCAW
- identifies two types of flowmeters
- explains the purpose of a regulator

**Presenting/Reporting**

- demonstrates effective use of one or more communication media:
  - e.g., *Written:* spelling, punctuation, grammar, basic format
  - Oral:* voice projection, language
- uses correct grammatical conventions and technical terms
- communicates information in a logical sequence

**PERFORMANCE ASSESSMENT**

CRITERIA	STUDENT RATING	STANDARD	COMMENTS
Preparation and Planning	4 3 2 1 0	3	
Content/Theory	4 3 2 1 0	3	
Presenting/Reporting	4 3 2 1 0	3	

**EQUIPMENT CHECKLIST: GMAW/FCAW START-UP AND SHUT-DOWN PROCEDURES**

**Semi-automated/Automated Welding: FAB1048-3**

**STANDARD:** all steps to be performed correctly and in the proper sequence

Name: \_\_\_\_\_

Date: \_\_\_\_\_

**\*START-UP PROCEDURES**

*The student:*

- checks the condition of the work station, welding equipment and personal protective equipment
- puts up adequate screening for people in the immediate area
- ensures proper ventilation
- makes sure all electrical connections are correctly attached and grounded
- checks for the proper shielding gas and wire electrode
- adjusts the machine for the appropriate wire speed, voltage and amperage
- turns on shielding gas and checks flowmeter
- checks shielding nozzle for gas obstructions
- uses the proper personal protective equipment
- posts a fire watch, if necessary
- turns on machine

**\*SHUT-DOWN PROCEDURES**

*The student:*

- carefully removes and cools all hot welding materials
- turns off power supply to welder
- shuts off shielding gas and closes the cylinder valve
- hangs up all cables and stores equipment as directed
- cleans up the work station

**REFLECTIONS/COMMENTS:**

**\* Procedures may differ according to each equipment manufacturer's recommendations.**

**General Outcome**

*The student will:*

- demonstrate safe GMAW and/or FCAW processes on light gauge mild steel and/or mild steel plate in the flat and horizontal positions

**PROCEDURE**

Weld Type:	GMAW Tee Fillet Weld
Position:	flat
Base Metal:	2 –10 gauge × 1" × 5" long (for FCAW, use 3/16" or 1/4" plate)
Preparation:	clean metal prior to fit-up
Number of Passes:	one
Machine Set-up:	according to manufacturer's recommendation
Fit-up:	as illustrated to the right

Bead Sequence:

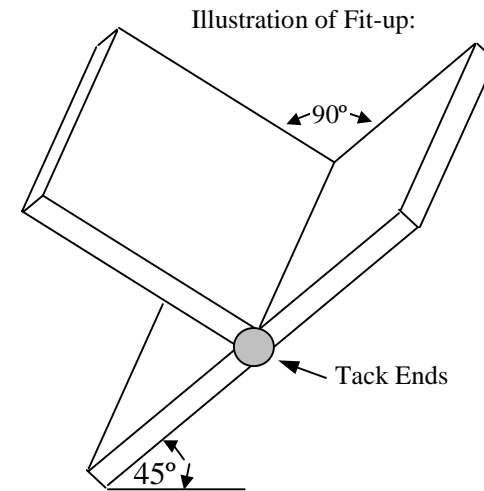
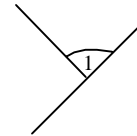

**TASK PERFORMANCE APPRAISAL**

Beads should be slightly convex, and of uniform width and height. Ripples are to be close, bullet shaped and free of voids, high spots, undercutting and coldlapping.

Characteristics of a desirable weld include:

- slightly convex bead
- uniform height
- consistent ripples
- top/bottom edges of weld are even
- no visible structural defects; e.g., undercut, porosity
- equal leg.

*Comments:*

**General Outcome**

*The student will:*

- demonstrate safe GMAW and/or FCAW processes on light gauge mild steel and/or mild steel plate in the flat and horizontal positions

**PROCEDURE**

Weld Type:	GMAW Lap Joint Fillet Weld
Position:	horizontal
Base Metal:	2 – 10 gauge × 1" × 5" long (for FCAW, use 3/16" or 1/4" plate)
Preparation:	clean metal prior to weld
Number of Passes:	one
Machine Set-up:	according to manufacturer's recommendation
Fit-up:	as illustrated to the right

Bead Sequence:

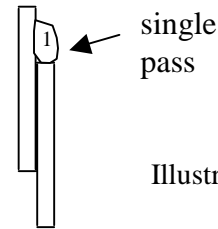
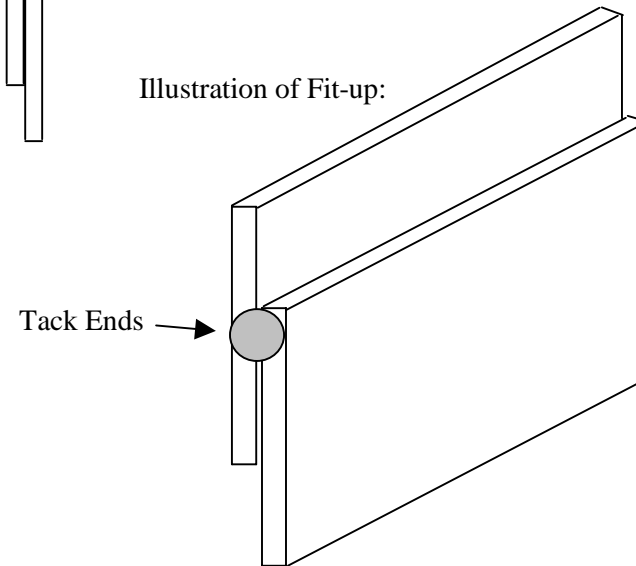

Illustration of Fit-up:



**TASK PERFORMANCE APPRAISAL**

Beads should be slightly convex, and of uniform width and height. Ripples are to be close, bullet shaped and free of voids, high spots, undercutting and coldlapping.

Characteristics of a desirable weld include:

- slightly convex bead
- uniform height
- consistent ripples
- top/bottom edges of weld are even
- no visible structural defects; e.g., undercut, porosity.

*Comments:*

**General Outcome**

*The student will:*

- outline the advantages and disadvantages of FCAW processes versus other forms of arc welding processes

**Standard**  
Performance rating of 2 for each applicable task.

**Rating Scale**

- The student:*
- 4 exceeds defined outcomes. Plans and solves problems effectively and creatively in a self-directed manner. Tools, materials and/or processes are selected and used efficiently, effectively and with confidence. *Quality, particularly details and finishes, and productivity are consistent and exceed standards.*
  - 3 meets defined outcomes. Plans and solves problems in a self-directed manner. Tools, materials and/or processes are selected and used efficiently and effectively. *Quality and productivity are consistent.*
  - 2 meets defined outcomes. Plans and solves problems with limited assistance. Tools, materials and/or processes are selected and used appropriately. *Quality and productivity are reasonably consistent.*
  - 1 meets defined outcomes. Follows a guided plan of action. A limited range of tools, materials and/or processes are used appropriately. *Quality and productivity are reasonably consistent.*
  - 0 has not completed defined outcomes. Tools, materials and/or processes are used inappropriately.

**TASK PERFORMANCE CRITERIA**

*The student:*

**Preparation and Planning**

- sets goals and describes steps to achieve them
- uses personal initiative to formulate questions and find answers
- accesses a range of relevant in-school/community information sources
- interprets, organizes and combines information into logical sequence
- records information accurately with appropriate supporting detail and uses correct technical terms
- plans and uses time effectively

**Content/Theory**

- describes the equipment and process of flux core arc welding
- lists six advantages of FCAW processes; e.g.:
  - good weld appearance; smooth and uniform with excellent contour on horizontal fillet welds
  - high quality weld metal deposits
  - suitable for welding many steel types and thicknesses
  - reduced distortion when compared to SMAW
  - high tolerance for contaminants that may cause weld cracking
  - the visible arc is easy to use

**Content/Theory (continued)**

- lists four disadvantages of FCAW processes; e.g.:
  - slag removal is necessary
  - presently limited to welding ferrous metals and nickel-based alloys
  - equipment is more expensive to purchase than that required for SMAW
  - more smoke and fumes are generated, therefore requiring suitable exhaust removal equipment

**Presenting/Reporting**

- demonstrates effective use of one or more communication media:
  - e.g., Written: spelling, punctuation, grammar, basic format*
  - Oral: voice projection, language*
  - Audio-visual: techniques, tools*
- uses correct grammatical conventions and technical terms
- provides an introduction that describes the purpose of the project
- communicates information in a logical sequence

**PERFORMANCE ASSESSMENT**

CRITERIA	STUDENT RATING	STANDARD	COMMENTS
Preparation and Planning	4 3 2 1 0	3	
Content/Theory	4 3 2 1 0	3	
Presenting/Reporting	4 3 2 1 0	3	

**General Outcomes**

*The student will:*

- describe the characteristics of a desirable flux core arc weld
- demonstrate safe FCAW practices and perform:
  - fillet welds on mild steel plate in the flat, horizontal and vertical positions
  - groove welds on mild steel plate in the flat position

**Standard**  
Performance rating of 3 for each applicable task.

**Rating Scale**

- The student:*
- 4 exceeds defined outcomes. Plans and solves problems effectively and creatively in a self-directed manner. Tools, materials and/or processes are selected and used efficiently, effectively and with confidence. *Quality, particularly details and finishes, and productivity are consistent and exceed standards.*
  - 3 meets defined outcomes. Plans and solves problems in a self-directed manner. Tools, materials and/or processes are selected and used efficiently and effectively. *Quality and productivity are consistent.*
  - 2 meets defined outcomes. Plans and solves problems with limited assistance. Tools, materials and/or processes are selected and used appropriately. *Quality and productivity are reasonably consistent.*
  - 1 meets defined outcomes. Follows a guided plan of action. A limited range of tools, materials and/or processes are used appropriately. *Quality and productivity are reasonably consistent.*
  - 0 has not completed defined outcomes. Tools, materials and/or processes are used inappropriately.

**TASK PERFORMANCE CRITERIA**

*The student:*

**Preparation and Planning**

- prepares self for task and develops an effective work plan
- identifies appropriate personal protective equipment and ventilation controls
- interprets and carries out instructions accurately
- plans and uses time in a logical manner
- attempts to solve problems prior to requesting help
- reads weld specifications and drawings to determine:
  - weld type and position
  - type of weldment and filler metal
  - equipment settings
  - welding techniques

**Use of Equipment and Materials**

- wears appropriate personal protective equipment
- follows accepted start-up, operation and shut-down procedures
- recognizes and corrects potential health and safety hazards
- maintains equipment according to manufacturer's recommendations
- fulfills clean-up responsibilities

**Content/Theory**

- lists and describes the characteristics of a desirable weld and test methods that are commonly used
- discusses strategies to improve weld quality; i.e.:
  - method of metal transfer
  - type of filler metal
  - machine set-up
  - manipulation

**Task Performance**

- uses flux core arc welding processes to produce two or more acceptable multi-pass fillet and/or butt welds in each of the following positions:
  - flat
  - horizontal
  - vertical
- uses flux core arc welding processes to produce two or more acceptable multi-pass groove welds in the flat position

**PERFORMANCE ASSESSMENT**

CRITERIA	STUDENT RATING	STANDARD	COMMENTS
Preparation and Planning	4 3 2 1 0	3	
Use of Equipment and Materials	4 3 2 1 0	3	
Content/Theory	4 3 2 1 0	3	
Task Performance	4 3 2 1 0	3	

**STANDARD:** all steps to be performed correctly and in the proper sequence

Name: \_\_\_\_\_

Date: \_\_\_\_\_

### **\*START-UP PROCEDURES**

*The student:*

- checks the condition of the work station, welding equipment and personal protective equipment
- puts up adequate screening for people in the immediate area
- ensures proper ventilation
- makes sure all electrical connections are correctly attached and grounded
- checks for the proper shielding gas and wire electrode
- adjusts the machine for the appropriate wire speed, voltage and amperage
- turns on shielding gas and checks flowmeter
- checks shielding nozzle for gas obstructions
- uses the proper personal protective equipment
- posts a fire watch, if necessary
- turns on machine

### **\*SHUT-DOWN PROCEDURES**

*The student:*

- carefully removes and cools all hot welding materials
- turns off power supply to welder
- shuts off shielding gas and closes the cylinder valve
- hangs up all cables and stores equipment as directed
- cleans up the work station

### **\*MAINTENANCE PROCEDURES**

*The student:*

- maintains wire drive system
- maintains gun assembly

**REFLECTIONS/COMMENTS:**

**\* Procedures may differ according to each equipment manufacturer's recommendations.**

**General Outcome**

*The student will:*

- demonstrate safe FCAW practices and perform:
  - fillet welds on mild steel plate in the flat, horizontal and vertical positions

**PROCEDURE**

Weld Type:	Tee Fillet Weld
Position:	flat
Base Metal:	2 – 3/8" × 2" × 5" long
Preparation:	clean base metal prior to weld
Filler Metal:	according to manufacturer's recommendation
Number of Passes:	three
Weld Size:	3/8" fillet
Machine Set-up:	according to manufacturer's recommendation
Fit-up:	as illustrated to the right

Bead Sequence:

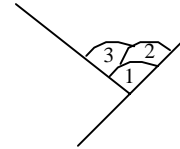
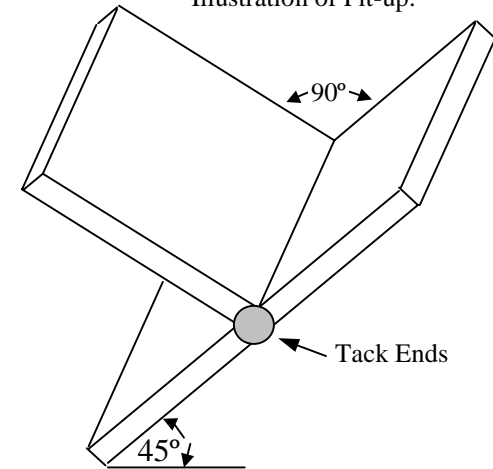

Illustration of Fit-up:



**TASK PERFORMANCE APPRAISAL**

Welds are to be free of visible structural defects and are to have uniform reinforcement.

Characteristics of a desirable weld include:

- equal leg (approximately 3/8")
- no visible structural defects; e.g., undercut
- even spacing on bead no. 2 and no. 3.

*Comments:*

**General Outcome**

*The student will:*

- demonstrate safe FCAW practices and perform:
  - fillet welds on mild steel plate in the flat, horizontal and vertical positions

**PROCEDURE**

Weld Type:	Tee Fillet Weld
Position:	horizontal
Base Metal:	2 – 3/8" × 2" × 5" long
Preparation:	clean base metal prior to fit-up
Filler Metal:	according to manufacturer's recommendation
Number of Passes:	three
Weld Size:	3/8" fillet
Machine Set-up:	according to manufacturer's recommendation
Fit-up:	as illustrated to the right

Bead Sequence:

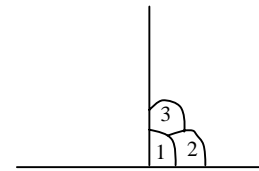
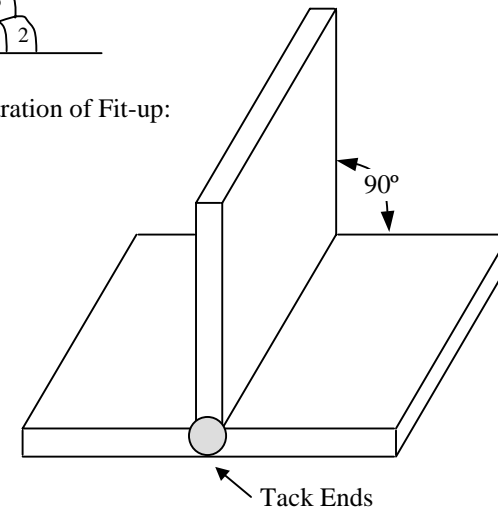

Illustration of Fit-up:

**TASK PERFORMANCE APPRAISAL**

Welds are to be free of visible structural defects and are to have uniform reinforcement.

Characteristics of a desirable weld include:

- equal leg (approximately 3/8")
- no visible structural defects; e.g., undercut
- even spacing on bead no. 2 and no. 3.

**Comments:**

**General Outcome**

*The student will:*

- demonstrate safe FCAW practices and perform:
  - fillet welds on mild steel plate in the flat, horizontal and vertical positions

**PROCEDURE**

- Weld Type: Tee Fillet Weld
- Position: vertical (i.e., up hand)
- Base Metal: 2 – 3/8" × 2" × 5" long
- Preparation: clean prior to fit-up
- Filler Metal: according to manufacturer's recommendation
- Number of Passes: three
- Weld Size: 3/8" fillet
- Machine Set-up: according to manufacturer's recommendation
- Fit-up: as illustrated to the right

Bead Sequence:

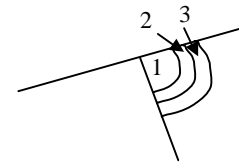
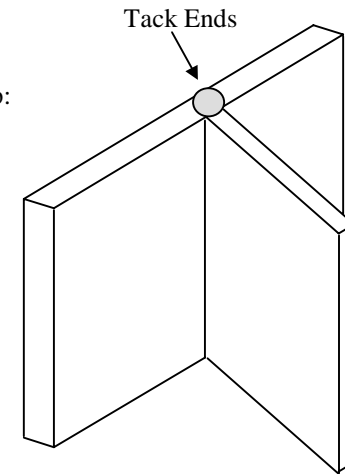

Illustration of Fit-up:



**TASK PERFORMANCE APPRAISAL**

**Welds are to be free of visible structural defects and are to have uniform reinforcement.**

Characteristics of a desirable weld include:

- equal leg (approximately 3/8")
- no visible structural defects; e.g., undercut
- consistent ripples
- straight edges at the sides of the weld.

*Comments:*

**General Outcome**

*The student will:*

- demonstrate safe FCAW practices and perform:
  - groove welds on mild steel plate in the flat position

**PROCEDURE**

Weld Type:	Single Vee Butt Joint Weld
Position:	flat
Base Metal:	2 – 3/8" × 2" × 5" long Backer: 3/16" × 1/2" × 5" long
Preparation:	30° bevel, no land; i.e., no root face
Filler Metal:	according to manufacturer's recommendation
Number of Passes:	as required
Machine Set-up:	according to manufacturer's recommendation
Fit-up:	as illustrated at the right; root opening: 1/8" or as preferred

Illustration of Fit-up:

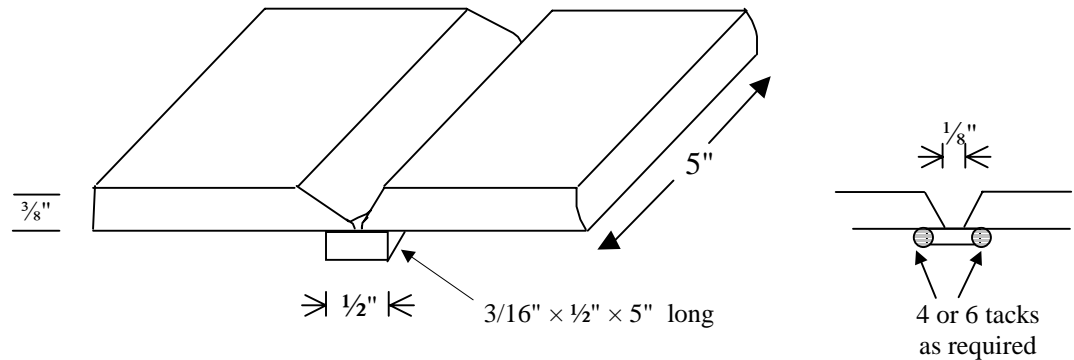

**TASK PERFORMANCE APPRAISAL**

Welds are to be free of visible structural defects and are to have uniform reinforcement.

Characteristics of a desirable weld include:

- build up slightly higher than base metal
- uniform bead(s) or ripples
- surface is free of splatter
- no signs of visible structural defects; e.g., undercut.

**Comments:**

**General Outcomes**

*The student will:*

- identify variables that affect the quality of flux core arc welds, and identify strategies to evaluate and improve weld quality
- demonstrate safe FCAW practices and perform groove welds on mild steel plate in the horizontal and vertical positions

**Standard**  
Performance rating of 3 for each applicable task.

**Rating Scale**

- The student:*
- 4 exceeds defined outcomes. Plans and solves problems effectively and creatively in a self-directed manner. Tools, materials and/or processes are selected and used efficiently, effectively and with confidence. *Quality, particularly details and finishes, and productivity are consistent and exceed standards.*
  - 3 meets defined outcomes. Plans and solves problems in a self-directed manner. Tools, materials and/or processes are selected and used efficiently and effectively. *Quality and productivity are consistent.*
  - 2 meets defined outcomes. Plans and solves problems with limited assistance. Tools, materials and/or processes are selected and used appropriately. *Quality and productivity are reasonably consistent.*
  - 1 meets defined outcomes. Follows a guided plan of action. A limited range of tools, materials and/or processes are used appropriately. *Quality and productivity are reasonably consistent.*
  - 0 has not completed defined outcomes. Tools, materials and/or processes are used inappropriately.

**TASK PERFORMANCE CRITERIA**

*The student:*

**Preparation and Planning**

- prepares self for task and develops an effective work plan
- identifies appropriate personal protective equipment and ventilation controls
- interprets and carries out instructions accurately
- plans and uses time in a logical manner
- attempts to solve problems prior to requesting help
- reads weld specifications and drawings to determine:
  - weld type and position
  - type of weldment and filler metal
  - equipment settings
  - welding techniques

**Use of Equipment and Materials**

- wears appropriate personal protective equipment
- follows accepted start-up, operation and shut-down procedures
- recognizes and corrects potential health and safety hazards
- maintains equipment according to manufacturer's recommendations
- fulfills clean-up responsibilities

**Content/Theory**

- lists and describes the characteristics of a desirable weld and test methods that are commonly used
- identifies variables that affect weld quality; e.g.:
  - welding current and voltage
  - type of shielding gas/flux
  - diameter and type of filler metal
  - type and condition of equipment
  - welding technique
- identifies possible causes of welding defects; e.g.:
  - surface/subsurface porosity
  - lack of fusion
  - burn through
  - lack of penetration
  - coldlapping
- suggests strategies to improve weld quality; e.g.:
  - method of metal transfer
  - type of filler metal
  - machine set-up
  - manipulation
- suggests solutions to problems common to out of position welding

**Task Performance**

- uses flux core arc welding processes to produce two or more acceptable multi-pass groove welds in each of the following positions:
  - horizontal
  - vertical

**PERFORMANCE ASSESSMENT**

CRITERIA	STUDENT RATING	STANDARD	COMMENTS
Preparation and Planning	4 3 2 1 0	3	
Use of Equipment and Materials	4 3 2 1 0	3	
Content/Theory	4 3 2 1 0	3	
Task Performance	4 3 2 1 0	3	

**EQUIPMENT CHECKLIST: FCAW SET-UP, MAINTENANCE AND TROUBLESHOOTING PROCEDURES**

**Flux Core Arc Welding 2: FAB3048-2**

**STANDARD:** all steps to be performed correctly and in the proper sequence

Name: \_\_\_\_\_

Date: \_\_\_\_\_

**\*START-UP PROCEDURES**

*The student:*

- checks the condition of the work station, welding equipment and personal protective equipment
- puts up adequate screening for people in the immediate area
- ensures proper ventilation
- makes sure all electrical connections are correctly attached and grounded
- checks for the proper shielding gas and wire electrode
- adjusts the machine for the appropriate wire speed, voltage and amperage
- turns on shielding gas and checks flowmeter
- checks shielding nozzle for gas obstructions
- uses the proper personal protective equipment
- posts a fire watch, if necessary
- turns on machine

**\*SHUT-DOWN PROCEDURES**

*The student:*

- carefully removes and cools all hot welding materials
- turns off power supply to welder
- shuts off shielding gas and closes the cylinder valve
- hangs up all cables and stores equipment as directed
- cleans up the work station

**\*MAINTENANCE PROCEDURES**

*The student:*

- maintains wire drive system
- maintains gun assembly

**\*TROUBLESHOOTING PROCEDURES**

*The student:*

- diagnoses problems related to malfunctioning FCAW equipment
- demonstrates appropriate corrective measures for malfunctioning FCAW equipment

**REFLECTIONS/COMMENTS:**

**\* Procedures may differ according to each equipment manufacturer's recommendations.**

**General Outcome**

*The student will:*

- demonstrate safe FCAW practices and perform groove welds on mild steel plate in the horizontal and vertical positions

**PROCEDURE**

Weld Type: Single Vee Butt Joint Weld

Position: horizontal

Base Metal: 2 – 3/8" × 2" × 5" long  
 Backer: 3/16" × 1/2" × 5" long

Preparation: 30° bevel, no land; i.e., no root face

Filler Metal: according to manufacturer's recommendation

Number of Passes: as required (stringer beads)

Machine Set-up: according to manufacturer's recommendation

Fit-up: as illustrated at the right; root opening: 1/8" or as preferred

Illustration of Fit-up:

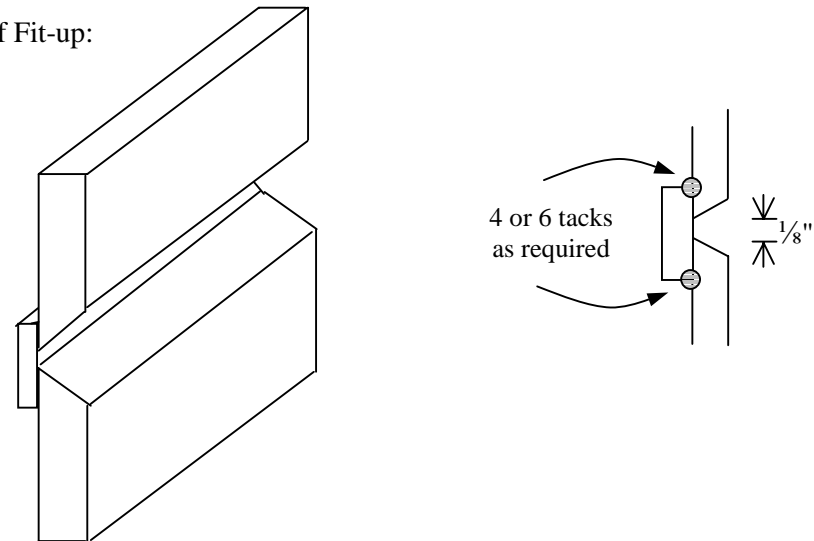

**TASK PERFORMANCE APPRAISAL**

**Welds are to be free of visible structural defects and are to have uniform reinforcement.**

Characteristics of a desirable weld include:

- build up slightly higher than base metal
- constant ripple on beads
- even spacing on beads
- no visible structural defects; e.g., undercut on top side of weld, improper lapping of stringer beads, sagging bead profile on bottom of weld.

*Comments:*

**General Outcome**

*The student will:*

- demonstrate safe FCAW practices and perform groove welds on mild steel plate in the horizontal and vertical positions

**PROCEDURE**

Weld Type: Single Vee Butt Joint Weld

Position: vertical; i.e., up hand

Base Metal: 2 – 3/8" × 2" × 5" long  
 Backer: 1/4" × 1/2" × 5" long

Preparation: 30° bevel, no land; i.e., no root face

Filler Metal: according to manufacturer's recommendation

Number of Passes: as required (weave weld)

Machine Set-up: according to manufacturer's recommendation

Fit-up: as per illustration;  
 root opening: 1/8" or as preferred

Illustration of Fit-up:

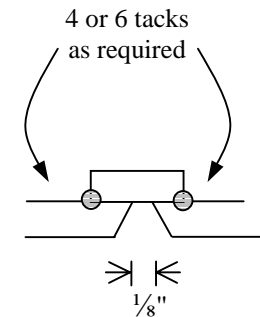
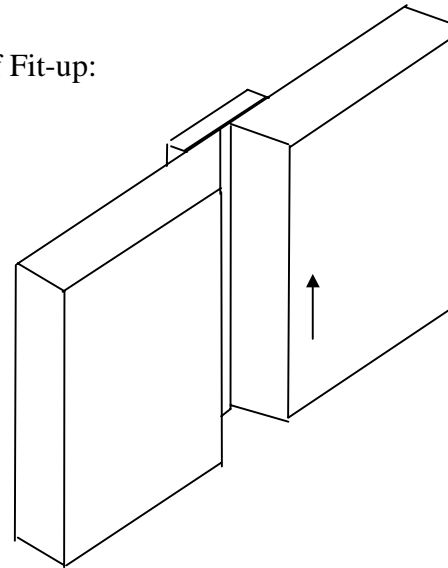

**TASK PERFORMANCE APPRAISAL**

**Welds should be free of visible structural defects and are to have uniform reinforcement.**

Characteristics of a desirable weld include:

- build up slightly higher than base metal
- constant ripple on weave beads
- no visible structural defects; e.g., undercut, crater at end of weld.

**Comments:**

## Fabrication Studies: Scope and Sequence

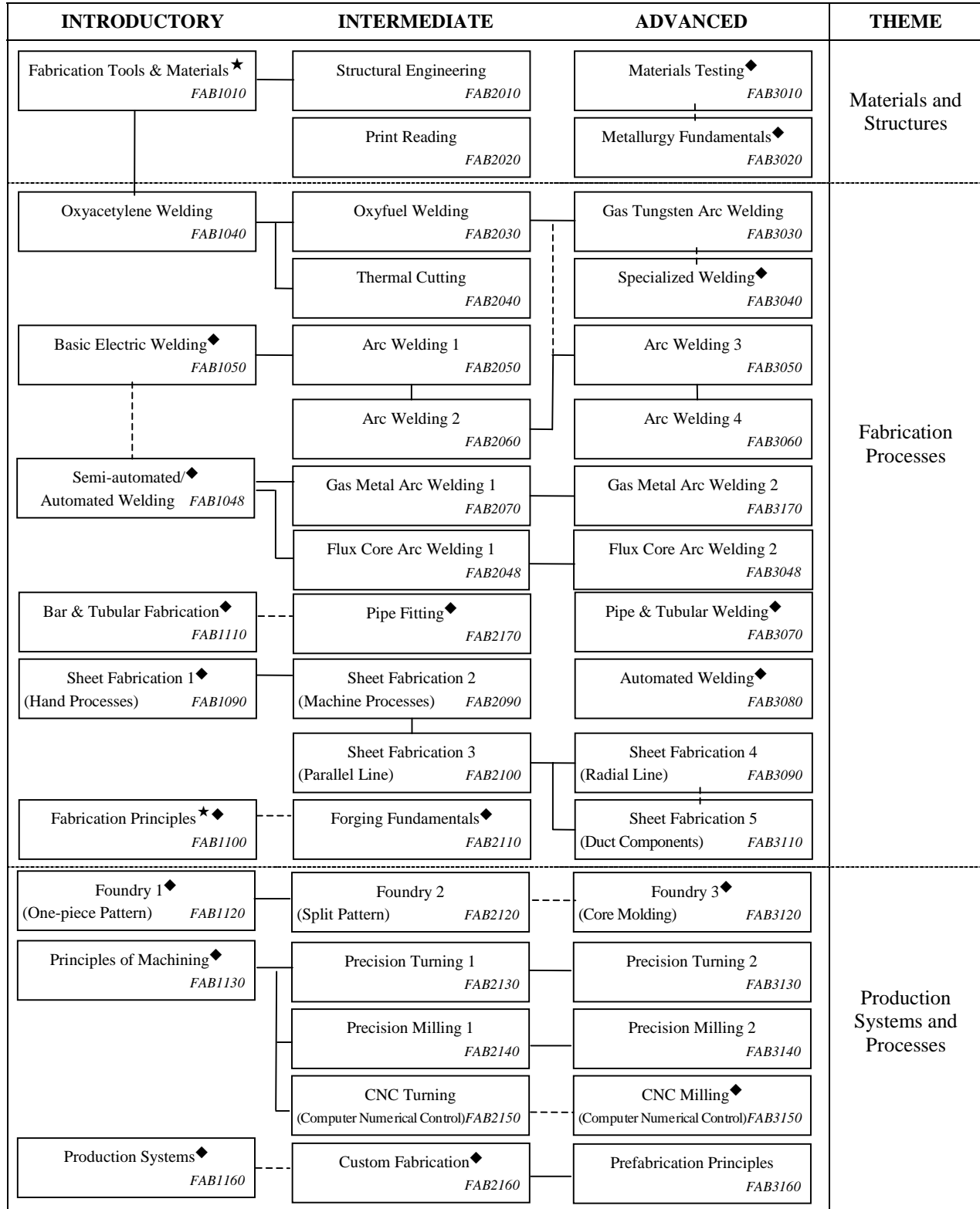

—— Prerequisite

----- Recommended sequence

★ Course provides a strong foundation for further learning in this strand.

◆ Refer to specific course for additional prerequisites.

## LINKAGES – Fabrication Studies: Extended Scope and Sequence

THEME	INTRODUCTORY	INTERMEDIATE	ADVANCED
Materials and Structures	Refining Rocks & Minerals <i>ENM2070</i>	Technical Drawing App. <i>DES2050</i>	
Fabrication Processes	Electrical Fundamentals <i>MEC1090</i>		Practicum A (Explosive Actuated Tools) <i>CTR3040</i>
	Engine Fundamentals <i>MEC1040</i>	Framing Systems 1 <i>CON2040</i>	Generation /Transformation <i>ELT3040</i>
		Exterior Finishing <i>CON2060</i>	
		Robotics 2 <i>ELT2140</i>	
		Plumbing Systems <i>CON2080</i>	
		Climate Control Systems <i>CON2090</i>	
	Metal Forming & Finishing <i>MEC1170</i>	Agri-structures <i>CON2100</i>	
Production Systems and Processes	Project Management <i>CON1120</i>	Multiple Materials <i>CON2120</i>	Tool Maintenance <i>CON3120</i>
	Mold Making & Casting <i>CON1180</i>		
	CAD Fundamentals <i>DES1050</i>	CAD Applications <i>DES2030</i>	Info Management Tools <i>INF3080</i>
	Fundamentals of Recycling <i>ENM1090</i>		Managing the Venture <i>EAI3010</i>
		Manufacturing Systems <i>CON2190</i>	Production Planning <i>CON3190</i>
		Product Development <i>CON2200</i>	Production Management <i>CON3200</i>